

Water-Proofed High-Performance GPS portable Rubidium Reference Source

PSRO-100

Smart GPS/SRO Reference Source

SmarTiming+® 1ns-Resolution Disciplining Technology Inside



APPLICATIONS

Military Reference/Test Source | Time/Frequency Source

KEY FEATURES

- GPS disciplined Rb clock : Auto-adaptive SmarTiming+ loop time constant, running at 1ns resolution
- Power supply voltage : DC 11.8V to 36V (standard)
Standard AC input 85- 264VAC / 47-63Hz
- Reference Frequency : Integrated GPS-locked Rubidium clock
- Phase time resolution and noise : $\leq 2\text{ps rms}$
- Output Frequency : 10MHz and 1PPS
- Integrated smart auto calibration
- Internal Bit Alarm
- RS232 standard interface : 9600 b/s
- Software application : Windows 98, XP
- GPS antenna types : Patch
- External PPS synchronization input along with NMEA messages synchronization
- Battery Operation Autonomy : up to 10 hours

Waterproof case :

- IP 65 in accordance with DIN 40050
- High temperature in accordance with MIL-STD-810 C, method 501.1
- Low temperature in accordance with MIL-STD-810 C, method 502.1
- Change of temperature in accordance with MIL-STD-810 C, method 503.1

SPECIFICATIONS

ELECTRICAL

Spec	PSRO-100	
Reference module	Standard	Options
RFOUT Frequency	10MHz	
PPSOUT Functionality	1PPS See SmarTiming+ section below	
Short Term Stability 1s 10s 100s	3E-11 1E-11 3E-12	(ordering code: S) 1E-11 3E-12 1E-12
Phase Noise (dBc/Hz) (RFOUT: 10 MHz) 1Hz 10Hz 100Hz 1kHz 10kHz	-75 -95 -125 -145 -145	(ordering code: S) -80 -100
Aging (Measured after 3 months of continuous operation)	< 5E-11 / month (typical: 3E-11 / month)	
Frequency Retrace Off/On (In stable temperature, gravity, pressure and magnetic field conditions)	< 5E-11 24 hr / 1 hr	
RFOUT Levels Output Impedance Harmonics Spurious $f_0 \pm 100\text{kHz}$ (DDSOUT Off)	Sine wave 0.5 Vrms ($\pm 10\%$ / 50 Ω) 50 $\Omega \pm 20\%$ < -25dBc < -80dBc	
GPS Antenna Connector	SMA	

SMARTIMING+® FUNCTIONALITY

Spec	PSRO-100
	Standard
PPSOUT Output level Pulse width (PW) or duty cycle	1PPS CMOS 0-5V (+- 20 mA sink/source) User settable, 0 to 1s in 133ns/step
PPSOUT to PPSREF Sync Error In Sync mode	< 50 ns No GPS PPSRef noise, $\pm 1^\circ\text{C}$ temp fluctuations
PPSOUT to PPSREF (DE) Programmable delay (In Track mode)	0 to 1 s in 133 ns steps
PPSOUT Holdover Time Stability	Within $\pm 2^\circ\text{C}$ 1 ns/24 hr
Smart Loop Time Constant Phase/Frequency User settable	Auto-adaptive 1000 to 100,000 sec User settable Sync/Track mode ** Selected by RS232 interface ** Sync: phase/time alignment; Track: frequency alignment

GPS ANTENNA

Spec	GPSReference	
	Standard	Option
Antenna Types Cable Length	Patch antenna kit 5 m / 16.4'	Roof antenna kit (ordering code RA).

POWER

Spec	PSRO-100
	Standard
Power Supply	DC 11.8V to 36V
Power Input Fluctuation	±10% of nominal supply voltage
Power Consumption @25°C	< 25W after warm-up
Connector Type	MSxxx
Battery power autonomy at 25°C	> 10 hours

ENVIRONMENT

Spec	PSRO-100
	Standard
Operating Temperature (at continuous operation without external power supply and at very low temperature , battery power autonomy may decreased down to 2 hours only TBC)	-20°C to 50°C in accordance with MIL-STD-810C method 501.1 and 502.1
Change of temperature	in accordance with MIL-810C, method 503.1
Storage	-25 to 60°C
Ingress protect	IP 65 in accordance with DIN 40050

PHYSICAL

Spec	PSRO-100	
	Standard	Option
Size	250x300x320 mm 9.84x11.81x12.6 in.	
Weight	8.5 kg / 18.74 lbs	

SYSTEM SUPPLY

Type	PSRO-100
1x	PSRO-100 box
1x	GPS antenna
1x	Cable Ac Power supply
1x	Cable Dc Power supply
1x	Cables SUB-D male/female for PC serial COM
1x	Cables SUB-D / MIL for PC serial COM for NMEA timing messages IN/OUT
1x	Operating manual & specifications on CD-ROM
1x	Optional: Stable32 "Time & Frequency" software application (ordering code: ST32) on CD-ROM

SOFTWARE UPGRADES

PSRO-100
Download the latest software upgrades at www.spectratime.com

ORDERING INSTRUCTIONS

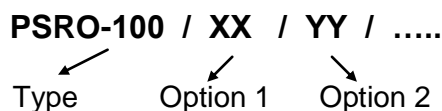

SYSTEM DESCRIPTION

The GPSReference integrates a smart Rubidium atomic clock and a GPS receiver. It has 3 basic modes of operation: Free Run, Track and Sync. The Free Run mode is when the Rubidium clock is not locked to a reference, and thus free running. The Track mode is when the reference is used to perform frequency alignment applications, whereas the Sync mode is when the reference is used to perform phase alignment applications.

As illustrated in Figure 1, when the GPSReference works in Track mode it uses the PPS_GPS as a reference (PPSREF) to align the frequency of the Rubidium clock. The frequency alignment is computed by an internal phase-time error signal that is generated by an internal PPS signal (PPSINT), which measures the signal at 1ns resolution through its SmarTiming+™ technology. The PPSINT then aligns the PPSREF phase.

In the Sync mode, the GPSReference phase aligns the PPSOUT to the PPSREF with the PPSINT reference signal, which uses SmarTiming+™ algorithm to 1) compare the PPSOUT and PPSREF signals at 1ns resolution within a +/-500ns dynamic range and 2) auto-adaptively align them.

The GPSReference has also the capability to dynamically analyze the stability of the PPSREF signal through the excellent mid-term frequency stability of the Rubidium technology. Thus, the 1PPS-GPS reference can be directly fed to the Rubidium clock without specific analysis of the internal optimization parameters of the GPS engine - i.e., number of satellites in view, signal to noise ratio, etc.

Figure 2 illustrates the typical frequency stability performance of the GPSReference, using its built-in 10MHz Rubidium reference clock.

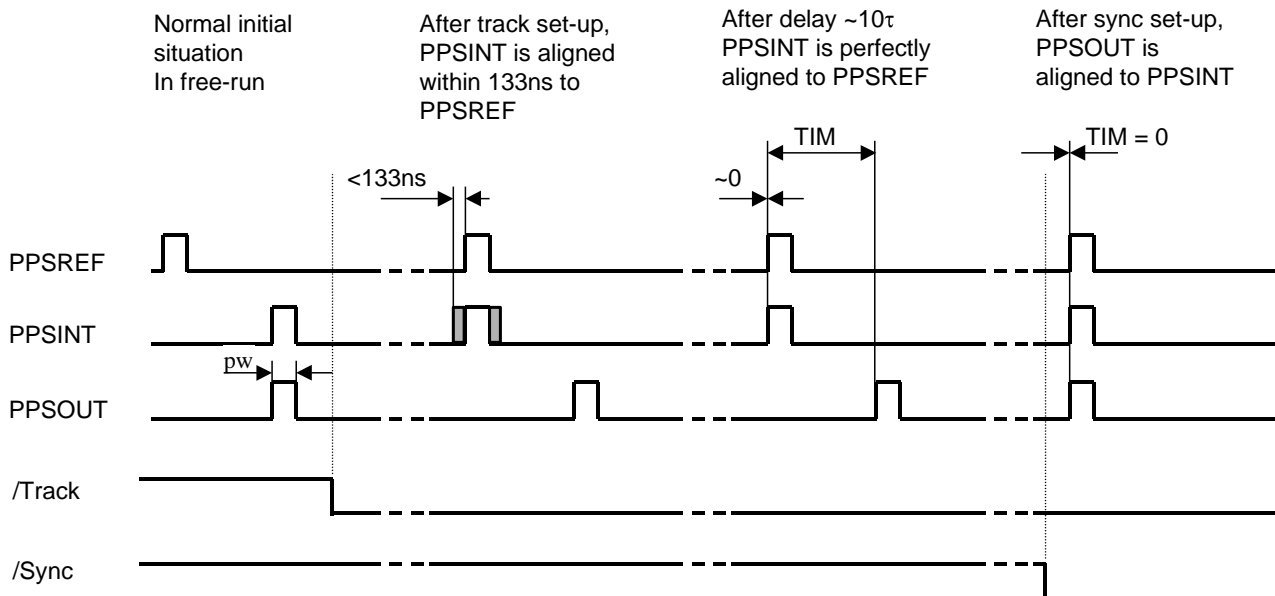

Figure 1 - Track & Sync Modes

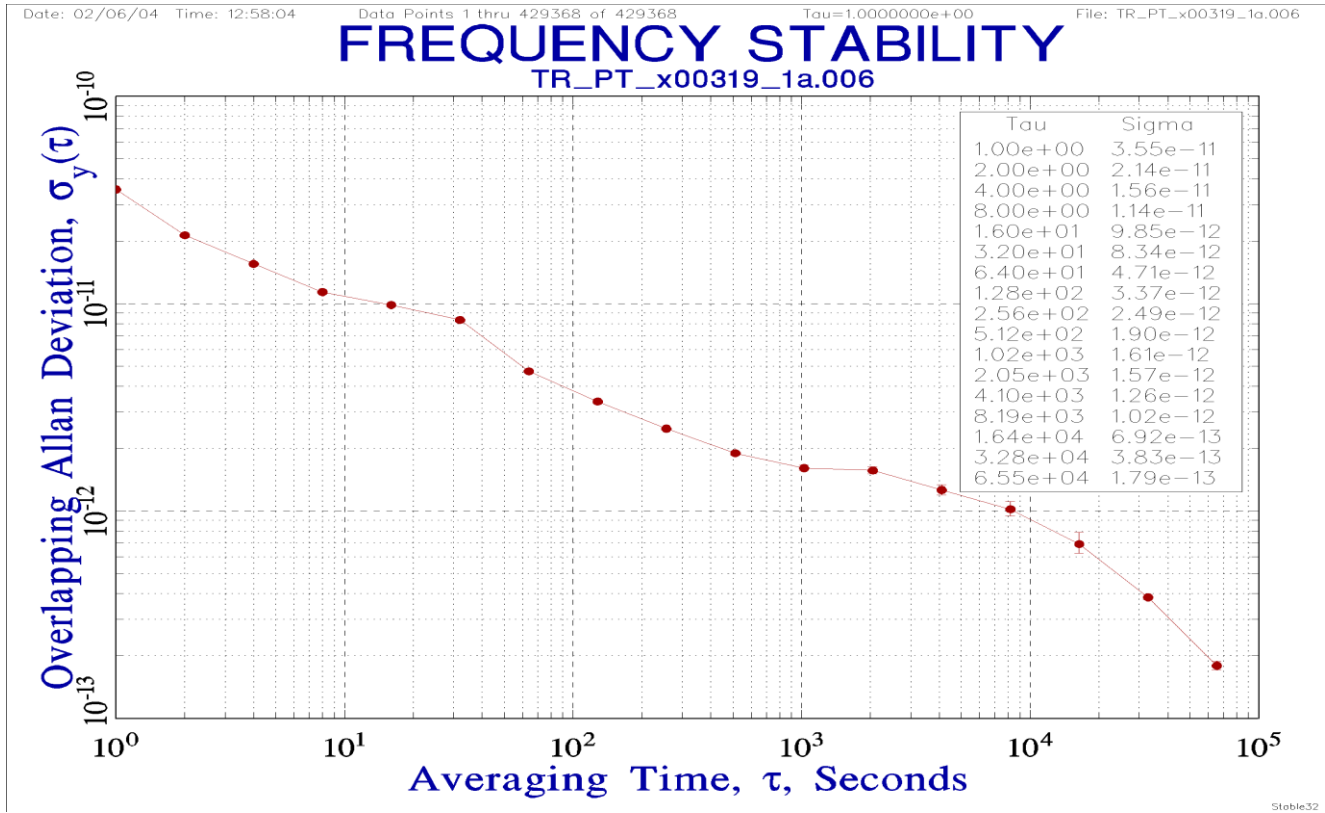
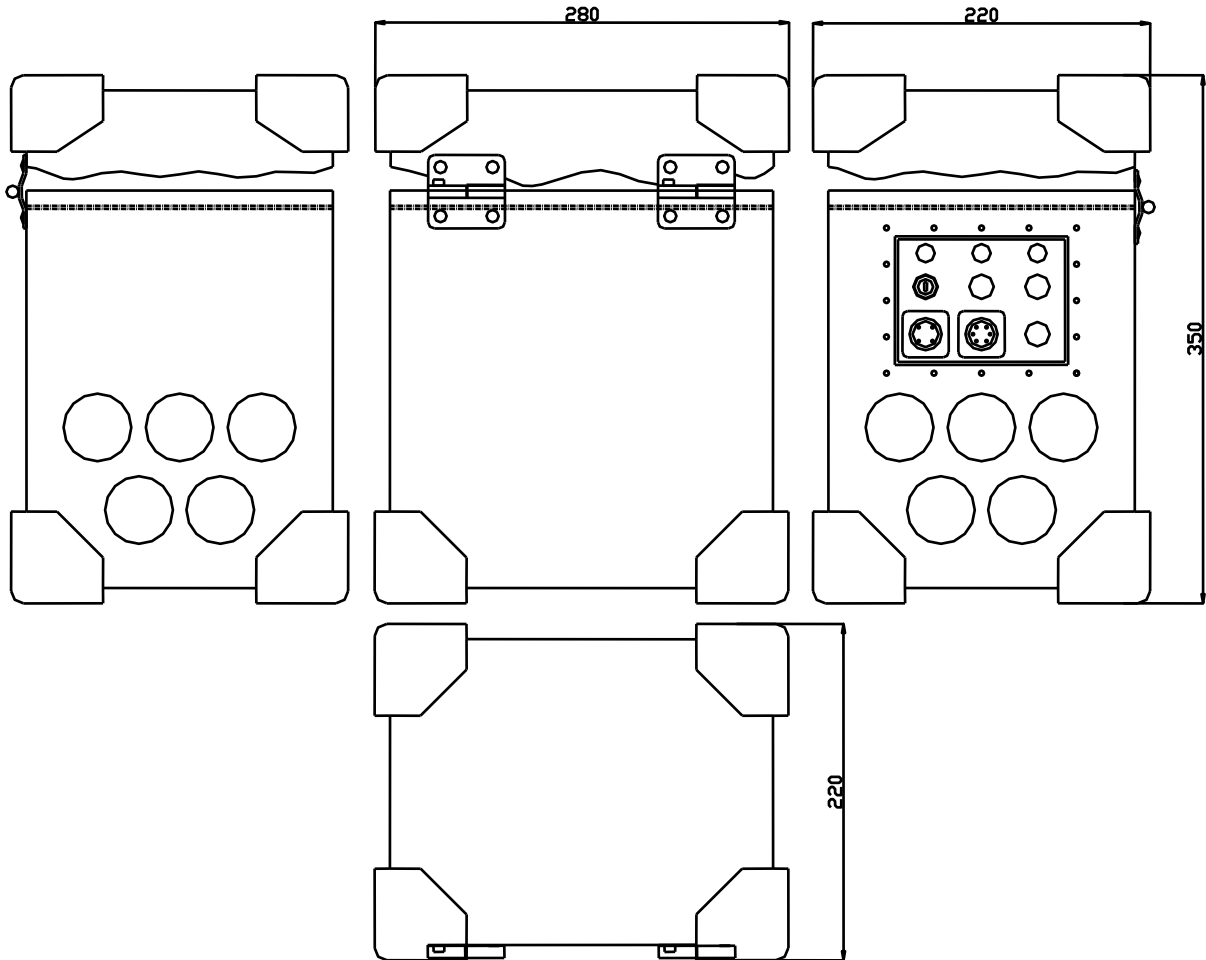

Figure 2 - Frequency Stability Performance

MECHANICAL DESCRIPTION

220X280X350mm Aluminium Box



RS-232 CONTROL & MONITORING COMMANDS

Frequency Adjustments & Rb Loop Monitoring Functions

The working and monitoring parameters of the Frequency Reference module are accessible for read and write operations through the serial RS-232 port (9600 bits/sec., no parity, 1 start bit, 8 data bits, 1 stop bit).

There are 2 basics commands as follows: *M* and *Cxxxx*

M<CR><LF>: monitors the basic internal signals of the atomic clock.

The returned answer is:

HH GG FF EE DD CC BB AA <CR> <LF>

Of which each returned byte is an ASCII coded hexadecimal value, separated by a <Space> character. All parameters are coded at full scale.

HH: Read-back of the user provided frequency adjustment voltage on pin 2 (0 to 5V)
GG: reserved
FF: peak voltage of Rb-signal (0 to 5V)
EE: DC-Voltage of the photocell (5V to 0V)
DD: varactor control voltage (0 to 5V)
CC: Rb-lamp heating current (Imax to 0)
BB: Rb-cell heating current (Imax to 0)
AA: reserved

Cxxxx<CR><LF>: output frequency correction through the synthesizer, by steps of 5.12×10^{-13} , where *xxxx* is a signed 16 bits word in hexa coded ASCII. This value is automatically stored in a EEPROM as last frequency correction which is applied after RESET or power-ON operation. In Track mode this correction is not in use. The function **FC**sdddd does the same, but the data format is different.

There is a command to set the SYNTH output frequency:

Txxxxxxxx<CR><LF>: Where *xxxxxxxx* is an unsigned 32 bits in hexa coded ASCII stored in

EEPROM. The frequency is changed after a reset $Frequency = \frac{xxxxxxxx}{2^{32}} \cdot 60MHz$

Timing & Locking Control Commands

Using the same data interface, the Reference module can accept the following basic ASCII commands: Data is in decimal ASCII code.

Command name	Syntax command	Data field (if any)	Response syntax	Response data (if any)
Identification	ID<CR><LF>	-	TNTSRO-aaa/rr/s.ss<CR><LF>	aaa: 100 rr: revision number s.ss: software version
Serial number	SN<CR><LF>	-	xxxxxx<CR><LF>	xxxxxx : 6 digits serial nbr
Status	ST<CR><LF>	-	s<CR><LF>	s:Status s=0 :warming up s=1 :tracking set-up s=2 :track to PPSREF s=3 :synch to PPSREF s=4 :Free Run. Track OFF s=5 :FR. PPSREF unstable s=6 :FR. No PPSREF s=7 :factory used s=8 :factory used s=9 :fault or Rb OOL
Set Tracking PPSINT - PSSREF	TRx<CR><LF>	x=0 : Track never x=1 : Track now x=2 : Track ever x=3 : Track now + ever x=9 : Interrogation	x<CR><LF>	x:Tracking commands status x=0 : Track OFF x=1 : Track ON (when Status 9 -> 4)
Set Synchronisation PPSOUT – PPSINT	SYx<CR><LF>	X=0 : Synch. never x=1 : Synch. now x=2 : Synch. ever x=3 : Synch. now + ever x=9 : Interrogation	x<CR><LF>	x:Synch. commands status x=0 : Synch. OFF x=1 : Synch. ON (When Status 1 -> 2)
Set PPSOUT delay	DEddddddd<CR><LF>	ddddddd=delay by 133ns step. Max 7499999 DE0000000 :synch to PPSREF	ddddddd<CR><LF>	ddddddd=delay by 133ns step. Max 7499999
Set PPSOUT Pulse Width	PWddddddd<CR><LF>	ddddddd=pulse Width by 133ns step. Max 7499999 PW0000000: no pulse	ddddddd<CR><LF>	ddddddd=Pulse Width by 133ns step. Max 7499999 0000000: no pulse
Time of day	TD<CR><LF>	-	hh:mm:ss<CR><LF>	hh:hours mm:minutes ss:seconds
Set time of day	TDhh:mm:ss<CR><LF>	hh:Hours mm:Minutes ss:seconds	hh:mm:ss<CR><LF>	hh:hours mm:minutes ss:seconds
Date	DT <CR><LF>		yyyy-mm-dd	yyyy : year mm : month dd : day
Set date	DT yyyy-mm-dd<CR><LF>	yyyy : year mm : month dd : day	yyyy-mm-dd	yyyy : year mm : month dd : day
Beat every second on serial port.	BTx<CR><LF>	x=0 : Stop beat x=1 : Effective Time interval PPSOUT vs PPSREF x=2 : Phase comparator x=3 : Both x=1 & x=2 x=4 : Beat Time of day x=5 : Beat status x=6 : Beat <CR><LF> x=7 : Beat Date, Time, Status x=A : Beat NMEA \$PTNTA, x=B : Beat NMEA \$PTNTS,B,	ddddddd<CR><LF> or sppp<CR><LF> or ddddddd sppp <CR><LF> or hh:mm:ss<CR><LF> s<CR><LF> <CR><LF> yyyy-mm-dd hh:mm:ss s	ddddddd : delay in 133ns step sppp:phase error in ns s: +/- signe hh:hours mm:minutes ss:secondes s: status yyyy:year, mm:month,dd:day
Set frequency adjustment	FCsdddd<CR><LF>	s=+/- signe dddd = limited within range : +32767/-32768 FC+99999 : interrogation	sdddd<CR><LF>	s: +/- signe dddd : frequ. Adj. in 5.12 x 10 ⁻¹³ step

Command name	Syntax command	Data field (if any)	Response syntax	Response data (if any)
Set frequency save. Integral part, when Status = 2, 3	FS x<CR><LF>	x=0 : never save x=1 : save every 24 hours x=2 : save right now x=3 : save actual freq. now x=9 : interrogation	x<CR><LF>	x=0 : never save x=1 : save every 24 hours
Set Tracking Window	TW ddd<CR><LF>	ddd = Half Tracking Window by 133ns step. From 1 to 255 ddd = 999 : interrogation	ddd<CR><LF>	ddd : Half Tracking Window by 133ns step.
Set no Alarm Window	AW ddd<CR><LF>	ddd = Half no Alarm Window by 133ns step. From 1 to 255 ddd = 999 : interrogation	ddd<CR><LF>	ddd : Half no Alarm Window by 133ns step.
Set tracking phase loop time constant	TC dddd<CR><LF>	dddd = Time constant in seconds (001000 to 999999) TC000000 : change to auto. (<)TC001000 : no change	Ddddd<CR><LF>	dddd : time constant in seconds
Set module customization	MC sxx [cc...c] <CR><LF>	s = L : Load parameter s = S : Store parameter ccc..c s = B : Load start behaviour s = A : Activate msg at start s = C : Cancel msg at start s = H : Load Help s = T : Load Data Type xx = 00..FF: msg number, ccc..c : new welcome message, up to 24 characters	cc..c<CR><LF> or d<CR><LF> or xy<CR><LF>	ccc..c : response to MCLxx or to MCHxx. d : 0, 1 response to MCBdd or xy : Data Type, response to MCTxx, x=0 RAM, x=1 eeprom, x=2 Flash, y=0 Byte, y=1 sByte, y=2 Word, y=3 sWoord, ... y=8 string ASCII, y=9 string binary
Set phase comparator Offset	CO sddd<CR><LF>	s : +/- signe ddd : limited with range + 127 / - 128 CO+999 : interrogation	sddd<CR><LF>	s : +/- signe ddd : offset in approx 1 ns steps
View PPSRef Sigma	VS <CR><LF>		ddd.d<CR><LF>	ddd.d : Sigma of PPSRef in ns. In tracking, Status 2, 3.
View Time constant	VT <CR><LF>		dddd<CR><LF>	dddd : Loop time constant now in use, in ns.
Raw phase adjust	RA sddd<CR><LF>	s : +/- signe ddd : limited with range + 127 / - 128	sddd <CR><LF>	s : +/- signe ddd : raw phase just asked in 133 ns steps
Reset micro controller	RESET <CR><LF>			(Identification & welcome message, GPS binary)

Standard GPS Antenna

A GPS patch antenna with 5 meters (16.4') of cable is included in the normal package. This antenna can be installed close to a window. If installed in a region susceptible to lightning, a surge arrestor must be installed. For the installation, please refer to our GPSReference user manual, section "Safe GPS Antenna installation".

Optional Rooftop GPS Antenna (Ordering code RA)

This kit contains the following items:

- a roof antenna
- a cable of 15 meter (49')
- a cable of 5 meter (16.4')
- a lightning arrestor

Custom GPS Antenna

The customer can install another antenna. In such case, the antenna connector of the device supplies 5V/30 mA for the amplifier. Please note that the device is CE tested only for an antenna cable less than 30 meters (98').

For the installation, please refer to our AN "Custom GPS Antenna Installation".

NMEA system description (For synchronization NMEA input & NMEA messages output)

RS232 speed specification: 9600 bits/sec., no parity, 8 data bits, 1 stop bit.

RS232 voltage specification

Buffer type: MAX 3311

State	Transmitting	Receiving
Space state (0)	+ 4 Volt	+ 2.4.. + 20 Volt
Mark state (1)	- 4 Volt	+ .8.. - 20 Volt

NMEA message \$GPRMC

`$GPRMC, hhnnss.00, a, llmm.mmmm, a, yymm.mmmm, a, , , ddmmyy, , , E*CS<CR><LF>`

`hhnnss.00`: hour,minute,second UTC

`a`: status of the clock A=ok, V= warning

`llmm.mmmm`: latitude in degree, minute or absent

`a`: N=north S=south

`yymm.mmmm`: longitude in degree, minute or absent

`a`: E=east W=west

`ddmmyy` day, month, year

`E`: always E

`CS`: check in hexa, xor of the characters between \$ and *

Electrical Bloc diagram

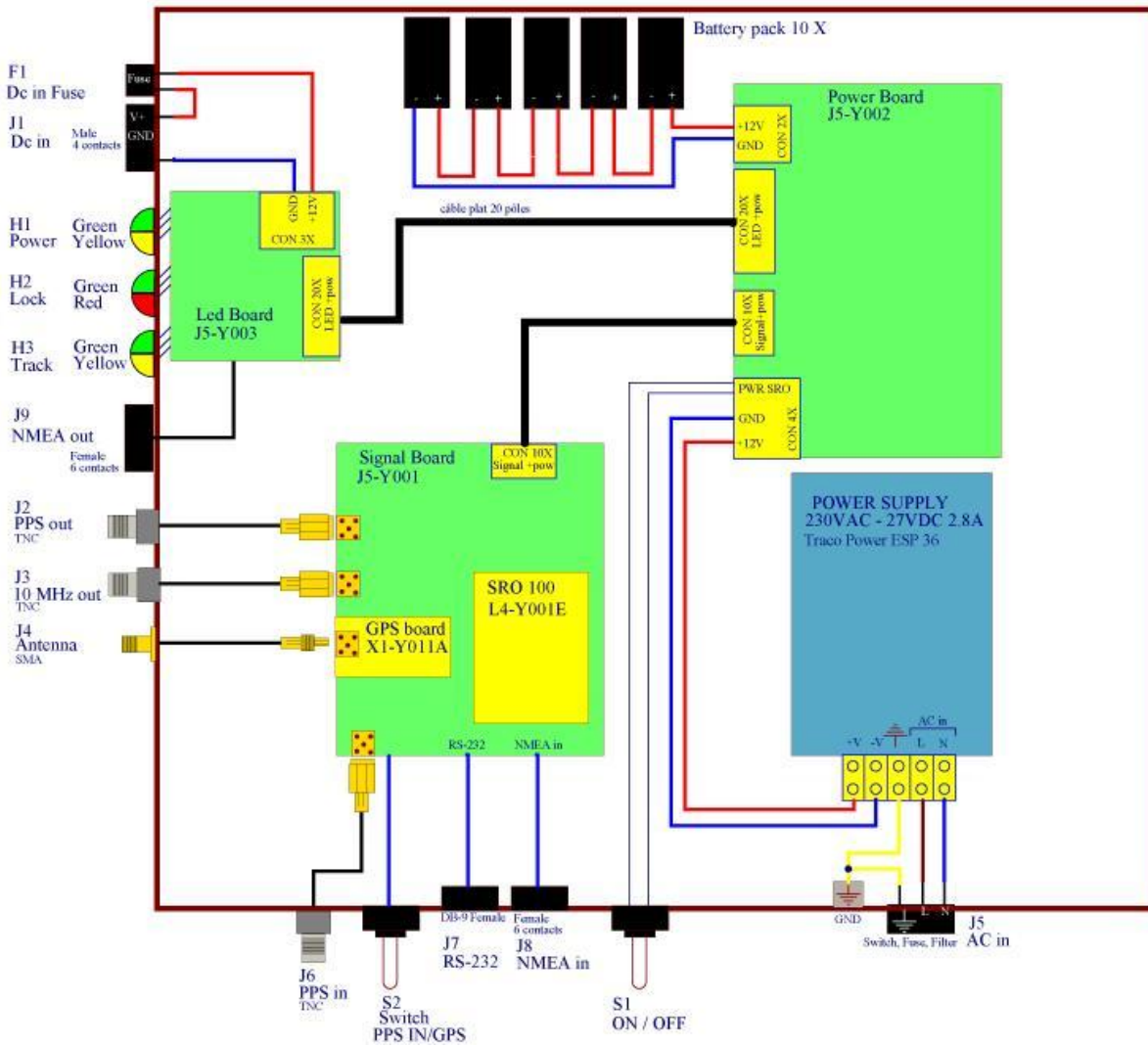

System I/O Interfaces

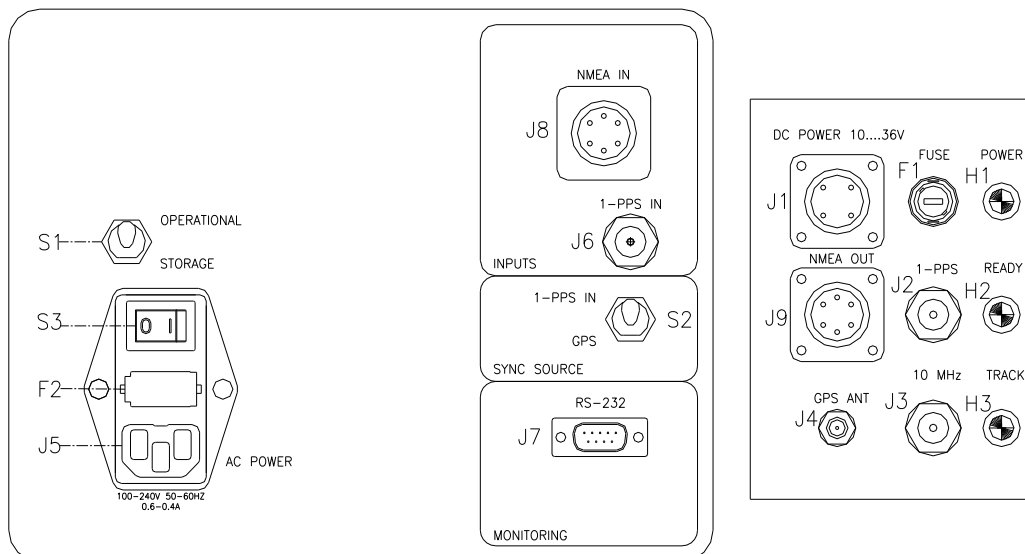

System I/O Interfaces

TOP PLATE			
N°	Type	Definition	I/O
J5	IEC PLUG	AC Input	I
J6	BNC	1-PPS Input	I
J7	SUB-D9-F	Serial communication RS232	I/O
J8	MIL-6P-M	NMEA Input	I
S1	SWITCH	On/Off switch DC	-
S2	SWITCH	PPS or GPS Sync selection switch	-
S3	SWITCH	On/Off switch AC	-
F2	FUSE	AC protection	-

SIDE PLATE			
N°	Type	Definition	I/O
J1	MIL-4P-F	DC Power 10-36V	I
J2	BNC	1PPS Output	O
J3	BNC	10MHz Output	O
J4	SMA	GPS Antenna connection	I
J9	MIL-6P-M	NMEA Output	O
H1	Green/Yellow LED	Power indicator	-
H2	Red/Green LED	Ready	-
H3	Green/Yellow LED	Track	-
F1	FUSE	DC 10-36V protection	-

CONNECTORS PINOUT			
N°	Type	Pin	Signal
J1	MIL-4P-F	A,B	GND
J1	MIL-4P-F	C,D	DC Power 10-36V
J7	SUB-D9-F	2	TXD
J7	SUB-D9-F	3	RXD
J7	SUB-D9-F	5	GND
J8	MIL-6P-M	A	(NMEA input) GND
J8	MIL-6P-M	D	(NMEA input) RXD
J9	MIL-6P-M	A	(NMEA output) GND
J9	MIL-6P-M	C	(NMEA output) TXD

CABLE PINOUT					
N°	Cable	Length	Type	Pin	Signal
J10, 20	Standard	3m	BNC	Center	Fréquence output
J10, 20	Standard		BNC	Blind.	GND
J30	Standard	3m	MIL-6P-F	A	GND
J30	Standard		MIL-6P-F	C	(NMEA output) TXD
J30	Standard		MIL-6P-F	D	(NMEA input) RXD
J40	Standard	3m	SUB-D9-F	2	(NMEA output) TXD
J40	Standard		SUB-D9-F	3	(NMEA input) RXD
J40	Standard		SUB-D9-F	5	GND
J50	TSM	3m	SUB-D9-M	2	(NMEA input, output) RXD, TXD
J50	TSM		SUB-D9-M	5	GND
J60	Standard	3m	MIL-4P-M	A,B	GND (white)
J60	Standard		MIL-4P-M	C,D	DC Power 10-36V (brown)

Cables Schematic

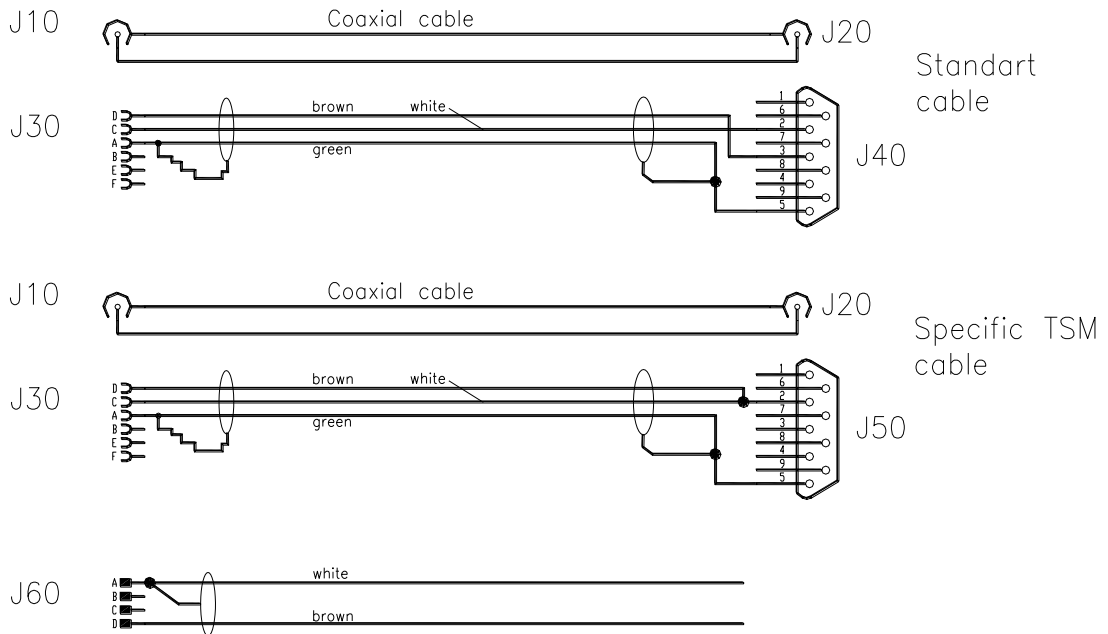

# Connect	Fonction	Type 1	Type 2	Fabricant
J1	Power supply 10.8 to 36V	4 pin fem	DMS 3102A14S-2S	DKK
J2	PPS out	BNC	??	??
J3	10 Mhz out	BNC	??	??
J4	Antenna	SMA	24_SMA-50-2-14/111_N	Huber&Suhner
J5	Power Supply 230VAC	2P+T	FN284-6-06	SCHURTER
J6	PPS in	BNC	??	??
J7	Monitoring	D-SUB 9P fem	DTS 9 SZ	Deltron
J8	Sync NMEA Input	6 pins male	DMS 3102A14S-6P	DKK
J9	Sync NMEA Output	6 pin male	DMS 3102A14S-6P	DKK
H1	Power	LED Green: when ext. power applied + battery loaded Flashing green : charging yellow : clock ON running on battery flashing : when battery too low		MARL
H2	Ready	LED Red: during warm-up or Rb failure Green: Rb OK	LED green if OK	MARL
H3	Track	LED Green: when tracked Flashing green : during tracking phase Yellow: when no reference		MARL

# Switch				
S1	Operational/Storage (CLK OFF)	interrupteur 2 positions		NKK
S2	GPS / 1PPS IN	interrupteur 2 positions		NKK
Accessories (if room available) (in Box cover)	24V power cable (3m with mating connector on PSRO only) 220V Standard Swiss plug cable harness for slave clock synchronization (3m) of TSM Patch antenna with 6m cable			

Base in standard operation conditions



Alternative Operation Conditions (cover closed or opened)

