

## Low Cost High Performance Frequency Rubidium Standard (HPFRS)

## High Precision & Performance Source



Telecom | Navigation | Broadcast | Defense | Instrument

Applications

**Table of Content :**

- 1. INTRODUCTION.....3**
- 2. LPFRS SYSTEM DESCRIPTION.....3**
- 2.1 PRINCIPLE OF OPERATION AND BASIC CONFIGURATION.....3**
- 2.2 PHYSICS PACKAGE .....4**
- 2.3 ELECTRONICS PACKAGE .....5**
  - 2.3.1 PRINCIPAL FUNCTIONS OF THE ELECTRONIC CIRCUITS .....5
- 3. HPFRS SPECIFICATIONS.....8**
- 4. HPFRS INSTALLATION AND OPERATION .....8**
- 4.1 INTRODUCTION.....8**
- 4.2 SHIPPING AND RECEIVING INFORMATION.....8**
- 4.3 MOUNTING.....8**
- 4.4 PIN FUNCTION LAYOUT.....10**
- 4.5 NORMAL OPERATION .....10**
- 4.6 SERIAL INTERFACE OPERATION .....11**
  - 4.6.1 INTRODUCTION .....11
  - 4.6.2 SERIAL INTERFACE CONNECTION .....11
  - 4.6.3 HPFRS-02 INTERNAL PARAMETERS MONITORING .....11
  - 4.6.4 CENTRE FREQUENCY ADJUSTMENT WITH THE SERIAL INTERFACE .....11
  - 4.6.5 CENTRE FREQUENCY READ-BACK .....12
- 4.7 HPFRS-01 LOCK MONITOR and XTAL MONITOR OUTPUTS .....12**
  - 4.7.1 'LOCK MONITOR' FUNCTIONAL DIAGRAM GENERATION.....12
  - 4.7.2 XTAL MONITORING OUTPUT:.....12
  - 4.7.3 LAMP MONITORING.....13
- 4.8 HPFRS-02 LOCK MONITOR .....13**
  - 4.8.1 TTL OR CMOS LEVEL 'LOCK MONITOR' GENERATION:.....13

# 1. INTRODUCTION

The Models HPFRS XX Rubidium Ultra-Stable Oscillators are sub-miniature, atomic resonance-controlled oscillators that provide an extremely stable frequency of 10 or 20 MHz (sinusoidal). The HPFRS is designed for navigation, communication and timing instruments requiring such extremely stable and precise frequency. This manual contains information about the operation and field maintenance of the HPFRS. Chapter 2 contains a general description of the unit. It also presents a basic theory of operation for a technician or engineer who requires a better understanding of the unit's operation. Chapter 3 lists all specifications and operation requirements of the HPFRS. Chapter 4 gives information on how to install and operate the unit. It is recommended that these chapters be read prior to operate the unit. This chapter describes also the possible interface connection for the monitoring of the internal parameters and for the centre frequency adjustment.

# 2. LPFRS SYSTEM DESCRIPTION

## 2.1 PRINCIPLE OF OPERATION AND BASIC CONFIGURATION

The HPFRS essentially consists of a voltage-controlled crystal oscillator (VCXO) which is locked to a highly stable atomic transition in the ground state of the  $Rb_{87}$  isotope. While the frequency of the VCXO is at the convenient standard frequency of 10 MHz, the  $Rb$  clock frequency is at 6.834XXX GHz in the microwave range. The link between the two frequencies is done through a phase-stabilized frequency multiplication scheme whereby a synthesized frequency is admixed to enable exact matching.

The  $Rb$  atoms are confined in a vapor cell at an elevated temperature. The cell is placed in a microwave resonator to which the microwave power derived from the VCXO is coupled. The  $Rb_{87}$  atoms in the cell occur with equal probability in the two hyperfine energy levels of the ground state ( $F=1$  and  $F=2$ ).

In order to detect the clock transition between these two levels, the atoms need to be manipulated in such a way that most of them occur in only one level. This is done by optical pumping via a higher lying state (P). Fig.

2-1 visualizes the atomic energy levels and transitions involved in the optical pumping process.

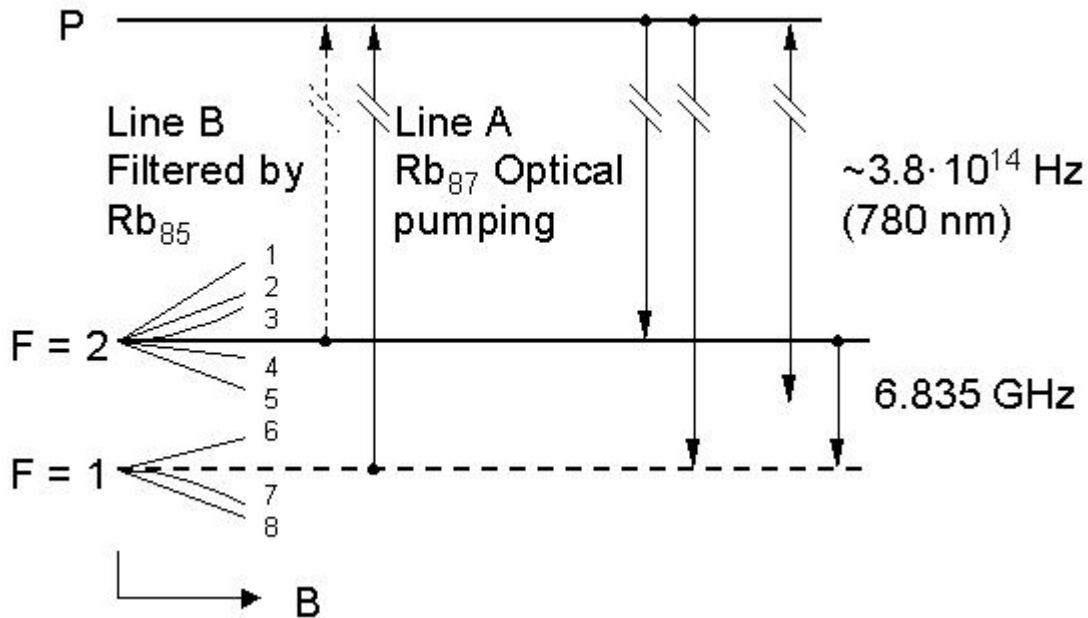

Fig. 2-1: Energy levels and transitions in  $Rb_{87}$  atoms during HPFRS operation

The pump light comes from a Rb resonance lamp which emits the light of  $Rb_{87}$  atoms. This light, which intersects the absorption cell, is filtered in such a way that mainly one optical frequency, which corresponds to a transition out of one of the two ground state levels (line A), enters the principal absorption region.

The pump light excites  $Rb_{87}$  atoms which are in the lower hyperfine level ( $F=1$ ) to the short-lived excited state P from which they decay to the two ground state levels ( $F=1,2$ ) with equal probability. Since pumping occurs continuously out of the  $F=1$  level, after some time, almost all atoms are found in the  $F=2$  level and no further absorption occurs.

The transmitted light level is detected by a photodiode after the cell. If now a microwave field resonant with clock transition  $F=2 @ F=1$  is coupled to the interaction region, the level  $F=1$  is repopulated and light absorption is enhanced. A sweep of the microwave field over the resonance is detected as a small dip in the transmitted light level after the cell.

This signal is fed into a synchronous detector whose output generates an error signal which corrects the frequency of the VCXO when its multiplied frequency drifts off the atomic resonance maximum.

The absorption cell is filled with metallic vapor which contains  $Rb_{85}$  and  $Rb_{87}$  isotopes and a buffer gas. Filtering of the pump light is achieved in the entrance region of the cell by absorption with  $Rb_{85}$  atoms which have an accidental overlap with one of the  $Rb_{87}$  resonance transitions (line B): integrated filter cell.

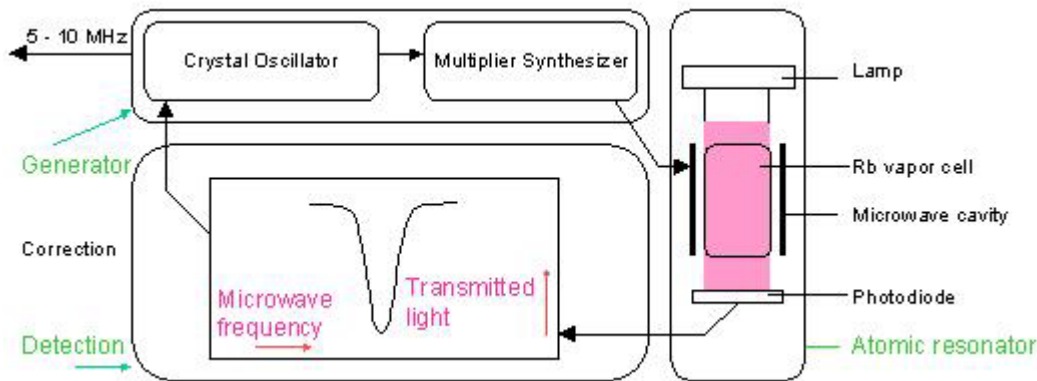

Fig. 2-2: Rubidium atomic clock principal block diagram

The principal function of the buffer gas is to keep the Rb atoms away from the cell walls and restrict their movements. As a result they are practically "frozen in place" for the interaction time with the microwave field. In this way the Doppler-effect is virtually removed and a narrow line width results.

The cell region is also surrounded by a so-called C-field coil which generates a small axial static magnetic field to resolve the Zeeman sub-transitions of the hyperfine line and select the clock transition, i.e. the one with the least magnetic sensitivity. To further reduce the magnetic sensitivity, the complete physics package is placed into nested magnetic shields.

Fig. 2-2 gives a basic overview of the different function blocks of the Rubidium atomic clock. The HPFRS consists of three different packages. The optical elements, which include the Rb absorption cell and microwave cavity, form the atomic resonator, while the electronics package is constituted of the generator and the detection circuitry.

## 2.2 PHYSICS PACKAGE

The main design characteristics of the physics package are its low power consumption, small size and mass, along with minimal environmental sensitivities and mechanical ruggedness.

All parts of the physics package are incorporated in a aluminium tube surrounded by magnetic shields. Inside this tube, lamp and cell sections form two separate blocks which operate at well-defined but different temperatures. The cylindrical tube is filled with polyurethane foam for low thermal conductivity. The lamp and cell sections are separated with a glass window. This configuration greatly reduces the thermal flow between

the blocks and the tube envelope. It allows a very compact design with low power consumption, short warm-up time and minimal environmental sensitivities.

Other design features which contribute to the compact design are:

- use of the integrated filter technique (IFT)
- use of a magnetron-type microwave resonator

The integrated filter technique which combines the optical filtering and pumping in one cell contributes also to the reliability since the configuration is simplified and the number of components reduced. The thermal capacitance of the cell assembly is relatively low. As a consequence, the necessary power during warm-up is greatly reduced.

The magnetron resonator is a cylindrical cavity loaded with a concentric capacitive-inductive structure (annular metal electrodes). It allows smaller cavity dimensions and concentrates the microwave field at the right region of the cell.

The Rb lamp is an electrode-less RF-discharge lamp: a heated glass bulb which contains Rb and a starter gas surrounded by an RF-coil.

Although the atomic clock transition frequency is inherently quite stable, there are second order influences which affect the frequency, i.e. temperature (buffer gas), light intensity (light shift = optical Stark effect), magnetic field (2nd order Zeeman effect). As a consequence, the temperatures of lamp and cell, the power of the lamp oscillator and the current in the C-field coil have to be carefully stabilized.

## 2.3 ELECTRONICS PACKAGE

### 2.3.1 PRINCIPAL FUNCTIONS OF THE ELECTRONIC CIRCUITS

The clock transition of a Rb resonator is a microwave transition at 6.834 .. GHz.

The microwave resonance occurs as a dip in the optical signal; i.e. in the Rb lamp light which, after transiting the cell, is detected by a photodiode.

The basic purpose of the electronics package is to synchronise the ingoing microwave frequency, derived from a quartz crystal oscillator, to this absorption dip. This is achieved by tuning the microwave frequency to maximum optical absorption.

Frequency variations of the microwave signal are transformed into DC current changes at the photodetector.

The dip, visualised in the photocurrent versus microwave frequency curve of Fig. 2-3, is very small: on the order of 1% of the total photocurrent which is however approximately 10 times higher compared to other commercial rubidium standards on the market.

Since DC detection of the dip is not feasible , an AC detection method is used for the following reasons:

- The dip amplitude is very small compared to the total photocurrent.
- The slope of the derivative of the dip photocurrent versus microwave frequency corresponds to roughly 1 nA/Hz. AC detection is the only solution to have a good signal/noise ratio since the photo-detector with associated amplifier are affected by flicker noise.

The AC method involves square wave frequency modulation of the microwave signal at a rate of fm ~330 Hz. As shown in Figure 2-3 the modulated microwave frequency flips between 2 discrete frequency values f1 et f2. The resulting photo- current i(t) appears then also (after the transient )at 2 discrete values i1 and i2 .

The difference between i1 and i2 produces the error signal used for the quartz crystal centre frequency adjustment until the mean value of f1 and f2 is exactly equal to the rubidium hyperfine frequency.

The clock microwave frequency of the Rb atoms in the vapour cell has a nominal value of 6834.684 MHz . This frequency is generated from a voltage controlled quartz oscillator (VCXO) which is multiplied up to 180 MHz .

Multiplication from 180 MHz to 6840 MHz is accomplished in one stage (x38 ) using a step-recovery diode mounted in the magnetron resonator inside the physics package.

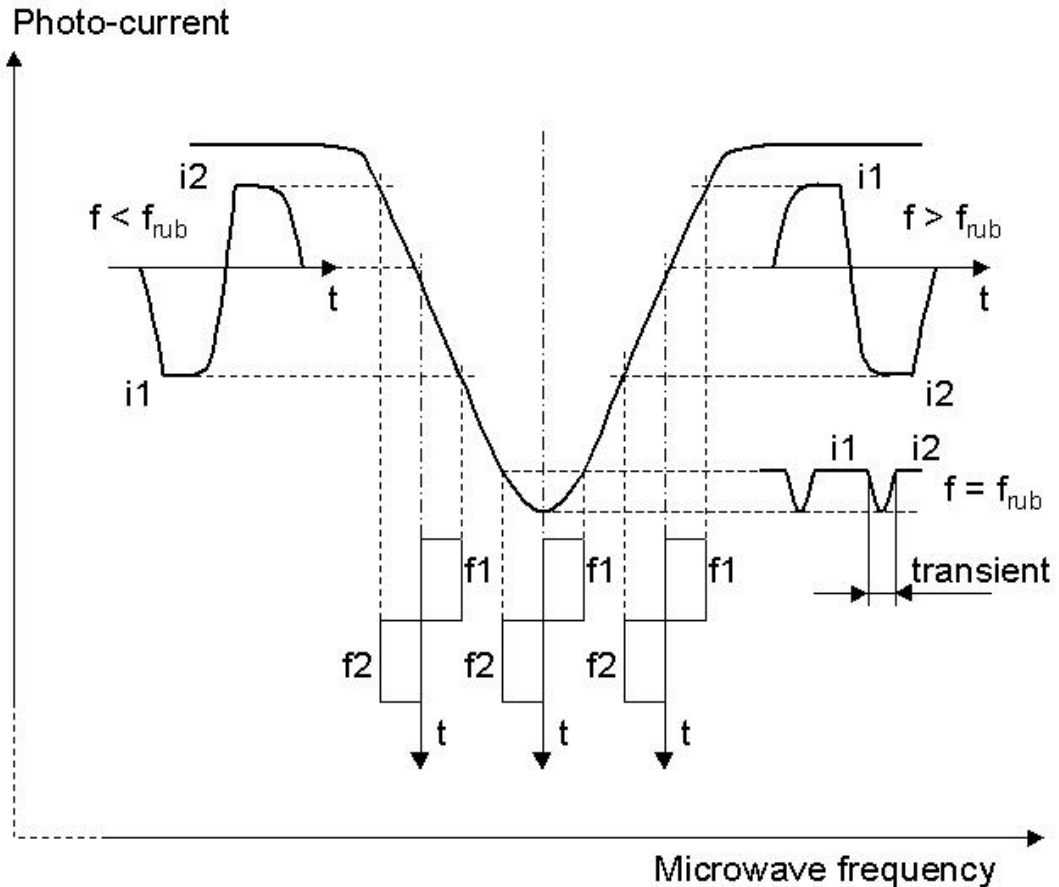

Fig. 2-3: Dip minimum detection

The 5.316... MHz phase modulation is introduced at the 180 MHz level. The 5.316... MHz spectrum is thus reproduced as a sideband of the 6840 MHz signal multiplied from the 20 MHz VCXO. The difference of the two frequencies corresponds to the Rb clock frequency.

This 5.316... MHz is generated by a synthesizer which is frequency modulated at the rate of  $f_m$  for dip detection.

The center frequency of the synthesizer is adjustable with step sizes of 12mHz in order to have the capability to adjust the HPFRS output frequency (10 MHz) with a resolution of  $2 \times 10^{-10}$  per step and, also, to compensate the frequency shift due to the buffer gas pressure inaccuracies in the cell.

The Rb light is generated by a plasma discharge in the Rb lamp. This is sustained by an RF oscillator which drives a coil surrounding the Rb lamp bulb. In addition, the lamp is heated to 140°C and stabilized within 0.2°C over the full operating temperature range. The temperature controlled heating power is generated by a wound resistive heater wire. Another part of the heating power is generated by the RF oscillator.

The Rb absorption cell is heated to ~85°C and also stabilized within 0.3°C over the full operating temperature range. The heating by a heater wire and the temperature control follows the same pattern as for the lamp heater.

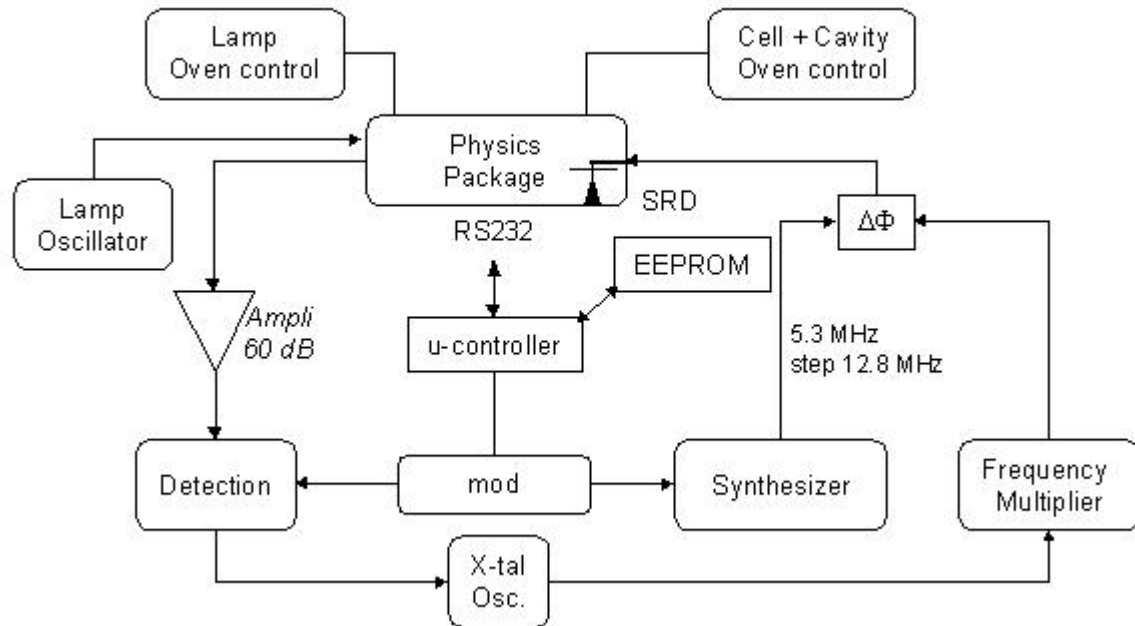

Fig. 2-4: HPFRS block diagram

The C-field coil within the physics package generates a magnetic field necessary for Rb spectral lines separation. This magnetic field allows fine tuning of the 10MHz output frequency by shifting the Rb frequency hyperfine transition by the second-order Zeeman effect.

A high stability current generator drives this coil; it is adjustable by the user in order to attain a fine analog or numerical resolution via a digital-to-analog converter.

The user interface consists of the RS-232 port for the monitoring of the internal parameters and for the center frequency adjustment. In addition, an analog frequency control input is available to the user for centre frequency adjustment by external potentiometer or external digital to analog converter.

The correct operation of the unit can be checked by a single open collector type output signal called 'lock monitor'. This lock monitor information is generated by the microcontroller and is a function of the following parameters:

- Light level intensity
- Rb signal level (detected signal)
- Heaters supply voltages
- RF section health.

The different alarm threshold levels corresponding to the different internal HPFRS electronics and physics parameters are programmed during the automatic adjustment procedure at the factory.

The power section of the HPFRS consists of three dc-dc converters. One is used for generating the internal 5V needed by the logic circuitry, the two other converters are used for the lamp and the cell heaters.

The synchronisation of the three converters is achieved by the use of a common ramp generator given by an internal 125kHz signal derived by direct division of the 20 Mhz main VCXO.

A detailed block diagram of the HPFRS is given by Fig. 2-4.

### 3. HPFRS SPECIFICATIONS

Follow this link

## 4. HPFRS INSTALLATION AND OPERATION

### 4.1 INTRODUCTION

This chapter of the manual contains information regarding the installation and operation of the TNT Model HPFRS. It is recommended to read this chapter carefully prior to operate the unit.

### 4.2 SHIPPING AND RECEIVING INFORMATION

The HPFRS is packaged and shipped in a foam-lined box. The unit is inspected mechanically and electrically prior to shipment. Upon receipt of the unit, a thorough inspection should be made to ensure that no damage has occurred during shipping. If any damage is discovered, please contact

SPECTRATIME SA  
PHONE: +41 32 732 16 66  
FAX: +41 32 732 16 67  
CH-2000 NEUCHATEL / SWITZERLAND

Should it be necessary to ship the unit back, the original case and packing should be used. If the original case is not available, a suitable container with foam-packing is recommended.

#### CAUTION

Care must be taken for the transportation of the HPFRS to ensure that the maximum acceleration due to a choc 50g/ 11ms is not exceeded.

HPFRS contains glass bulbs, crystal resonators and crystal filters.

When HPFRS integrated into an instrument, such instrument shall be packed in a suitable container, similar to containers generally use for the transportation of instruments like scope, video display or computer.

### 4.3 MOUNTING

The unit should be mounted with one of the two mounting planes in contact with a flat metal surface (0.1 mm rms or better). Mounting screws (4 x M3, stainless steel) should be tightened with a torque between 50 Ncm and 100 Ncm.

The heat transfer characteristics of the mounting surface must be adequate to limit the rise of the unit's base plate to <+68°C. Since the minimum total power consumption for proper Rb operation is around 165mA / 24V, the allowable environmental temperature (Tamax), for this mounting is:

$$T_{\text{amax}} = 68^{\circ}\text{C} - V_s \times I_s \times R_k$$

$V_s$  = Supply voltage in volts

Where:  $I_s$  = Min supply current in amperes (0.165A)

$R_k$  = Thermal Resistance between unit and ambient, °C/watt.

The maximal allowable environmental temperature (Tamin) is given by

$$T_{\text{amax}} = 68^{\circ}\text{C} - V_s \times I_s \times R_k$$

#### CAUTION

Care must be taken to ensure that the maximum operating temperature is not exceeded, (+ 68°C as measured at the unit's base plate)

This maximum temperature can be reached when operating the unit into forced air flow at 65°C or by mounting the unit into user equipment with thermal interface corresponding to a thermal resistance of 1 to 2 °C/W between the HPFRS unit and the ambient.

The HPFRS is a well shielded unit, using several magnetic shield layers as well as special RF shields for the RF section. Nevertheless, some consideration must be given to the operating location of the unit, regardless of its application. To minimise frequency offsets and/or non-harmonic distortion, the unit should not be installed near equipment generating strong magnetic fields such as generators, transformers, etc.

The general information for the mechanical interface of the HPFRS unit is given in the package drawing of Fig. 4-3

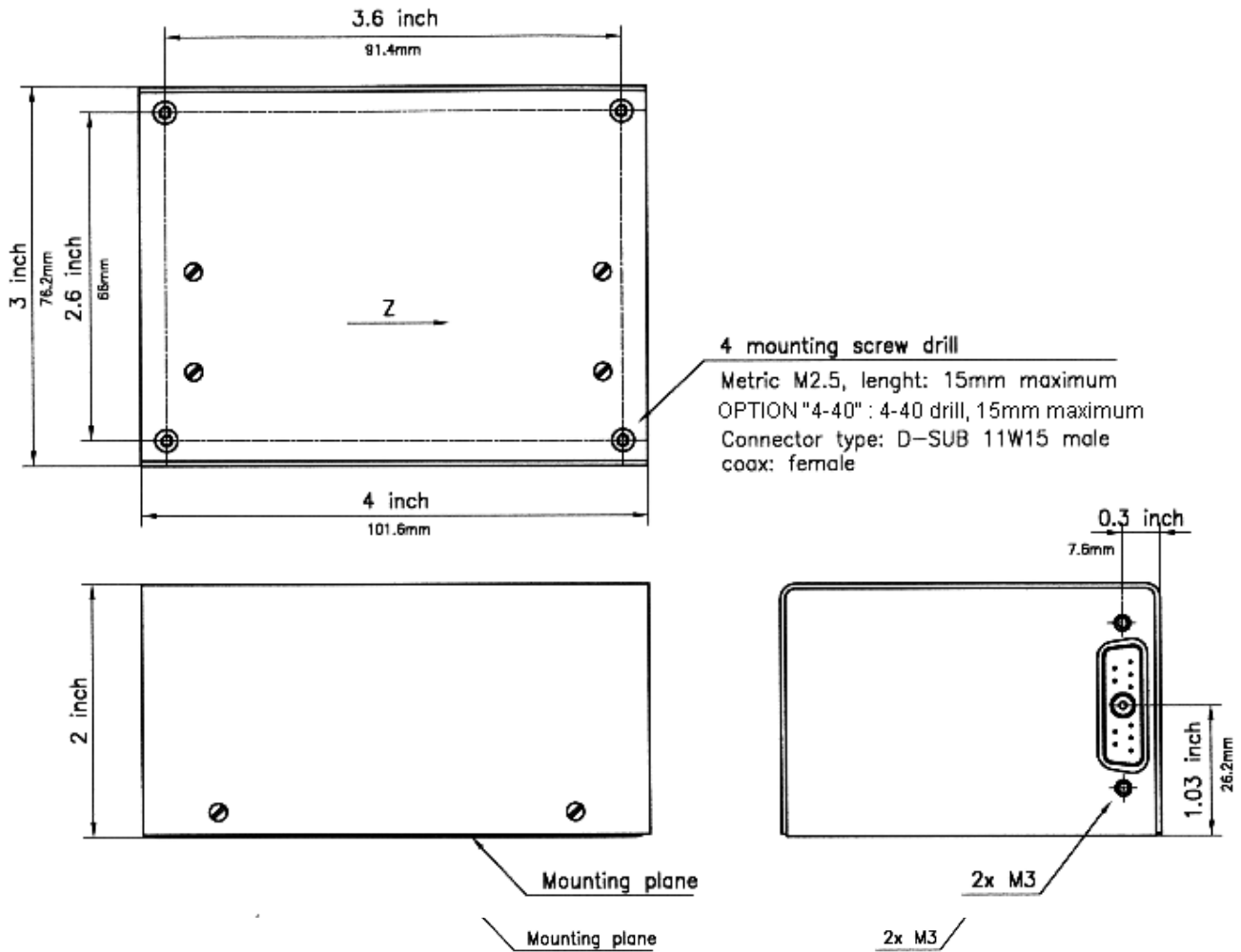

Fig. 4-3

#### 4.4 PIN FUNCTION LAYOUT

The complete pin layout for the sub-D connector is given in figure 4.4.

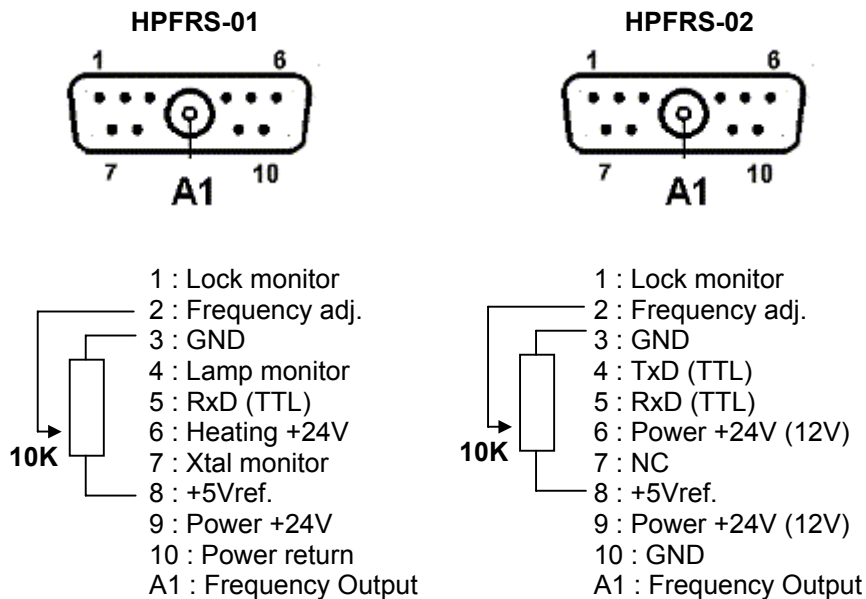

Fig. 4.4 (connector front view)

#### IMPORTANT NOTE:

The standard version of the HPFRS is equipped with sub-D type Cannon 11W1 male together with male coaxial connector.  
This configuration reduces the risks of damage to the coaxial HPFRS connector by incorrect manipulations.

#### 4.5 NORMAL OPERATION

When 24 Vdc is applied to pins 6, 9 (+) and 3, 10 (-), the unit will immediately begin to generate a 10 MHz signal from the crystal oscillator. Within approximately 8 minutes (standard version) after application of input power the unit will "lock". Hence the crystal is now stabilised by the atomic resonant frequency.

The unit is able to provide a single signal called 'lock monitor' (pin 1) which toggles when the internal crystal oscillator is locked to the Rb atomic resonance. (see chapter 4.7).

The centre frequency can be adjusted by external trimmer according to fig. 4.4 or by a stable DC voltage provided by the user.

#### ANALOG FREQUENCY ADJUSTMENT

The HPFRS is equipped with an analog frequency adjustment circuit which provides center frequency adjustment by applying an external voltage of 0 to 5V on Pin 2.

This analog voltage can be generated with an external potentiometer connected to Vref and GND (see pin function layout).

## 4.6 SERIAL INTERFACE OPERATION

### 4.6.1 INTRODUCTION

The HPFRS is equipped with a microcomputer, associated with multi-channel D/A converters, used for setting its parameters. This microcomputer is also used for the interrogation and detection of the Rb absorption 'dip'.

The built-in serial interface allows an automatic parameter adjustment during the manufacturing process as well as coarse and fine adjustment of the centre frequency.

All the working parameters are stored in a built-in EEPROM memory. In addition an 8 channel A/D converter is used for monitoring the main internal signals such as: light level, signal level, thermostats heating currents etc...

### 4.6.2 SERIAL INTERFACE CONNECTION

The data transfer from the HPFRS can be made by direct connection to a PC or standard terminal.

The data transfer parameters are the following:

bit rate : 1200 bits/s.

parity : none

start bit: 1

data bits: 8

stop bit: 1

#### IMPORTANT NOTE:

The serial HPFRS interface accepts the 0 to 5V level and a direct connection can be made. The HPFRS RxD input is protected and can accept  $\pm 12V$  RS 232 standard voltage also.

### 4.6.3 HPFRS-02 INTERNAL PARAMETERS MONITORING

The HPFRS-01 is only equipped with RxD pin on the connector. Therefore, it can only receive commands for frequency adjustment. (no monitoring capabilities by RS 232 interface).

Consequently, the HPFRS has no internal parameter monitoring capability.

### 4.6.4 CENTRE FREQUENCY ADJUSTMENT WITH THE SERIAL INTERFACE

Two single character commands are available to the user for centre frequency adjustment. This correction (coarse or fine) is automatically loaded into the internal EEPROM memory and becomes permanent.

**Cxx<CR>**: Coarse output frequency correction through the synthesiser, by steps of  $2 \times 10^{-10}$  for the HPFRS-01 and  $1 \times 10^{-9}$  per step for the HPFRS-02 model.

where xx is a signed 8 bits word (HEX coded).

#### Example for HPFRS-01 model:

'C7F<CR>' will produce  $+2.54 \times 10^{-8}$  freq. correction from the nominal value 0

'CFF<CR>' will produce  $-2 \times 10^{-10}$

'C00<CR>' return to the nominal value (factory setting)

'C80<CR>' will produce  $-2.56 \times 10^{-8}$  freq. correction from nominal value 0

#### Example for HPFRS-02 model:

'C7F<CR>' will produce  $+1.28 \times 10^{-7}$  freq. correction from the nominal value 0

'CFF<CR>' will produce  $-1 \times 10^{-9}$

'C00<CR>' return to the nominal value (factory setting)

'C80<CR>' will produce  $-1.27 \times 10^{-7}$  freq. correction from nominal value 0

**Fxx<CR>**: Fine output frequency correction through C-field, by steps of  $1 \times 10^{-11}$

where xx is a signed 8 bits word (HEX coded).

Example:

'F7F<CR>' :  $+1.27 \times 10^{-9} \pm 20\%$  freq. correction from the nominal value 0

'FFF<CR>' :  $-1 \times 10^{-11} \pm 20\%$  freq. correction from the nominal value 0

'F00<CR>' return to the nominal value 0

'F80<CR>'  $-1.28 \times 10^{-9} \pm 20\%$  freq. correction from nominal value 0

Please note that fine frequency correction is used at factory to set the HPFRS to the nominal frequency before delivery.

#### 4.6.5 CENTRE FREQUENCY READ-BACK

The HPFRS-01 is only equipped with RxD pin on the connector. Therefore, it can only receive commands for frequency adjustment. (no monitoring capabilities by RS 232 interface).

Consequently, the HPFRS has no centre frequency Read-Back capability.

### 4.7 HPFRS-01 LOCK MONITOR and XTAL MONITOR OUTPUTS

The HPFRS-01 contains a 'lock monitor' function which consist in a monitoring of the internal parameters like light level, Rb absorption 'dip' level, heaters monitoring etc.. and a comparison with nominal values. This principle of operation ensures the user that the HPFRS-01 VCXO is still locked correctly onto the Rb atoms resonance.

The 'lock monitor' output circuitry looks like an open collector output with some differences as shown by the two following diagrams:

#### 4.7.1 'LOCK MONITOR' FUNCTIONAL DIAGRAM GENERATION

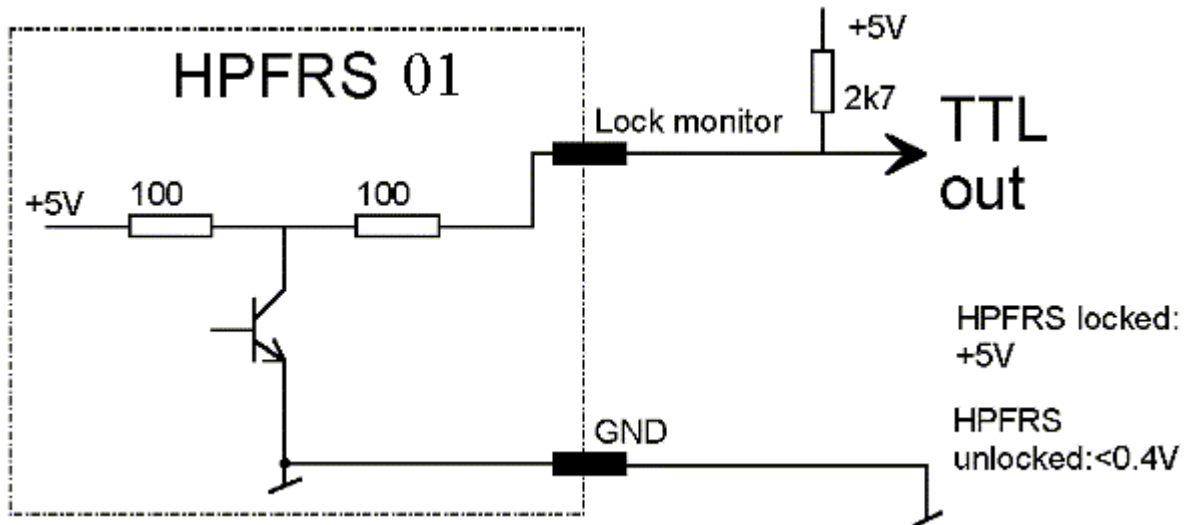

The lock monitor output can be directly connected to the CMOS load.

#### 4.7.2 XTAL MONITORING OUTPUT:

Xtal monitoring output corresponds to the signal used in the HPFRS for controlling the internal VCXO frequency

The full scale is ~ 10 V

The nominal value is ~ 4 to 6V

Output impedance : 10 kohm

The total frequency pulling range of the internal VCXO corresponds to  $\pm 30$  ppm . Such large tuning range is sufficient to compensate the ageing of the crystal for 20 years or more of continuous operation.

### 4.7.3 LAMP MONITORING

Lamp monitoring indicates the health of the rubidium lamp by measuring the light level and comparing it to its normal value.

Lamp ON: > 10V

Lamp OFF: > 1V

Output impedance: 1Mohm

## 4.8 HPFRS-02 LOCK MONITOR

The HPFRS-02 contains a 'lock monitor' function which consist in a monitoring of the internal parameters like light level, Rb absorption 'dip' level, heaters monitoring etc.. and a comparison with nominal values. This principle of operation ensures the user that the HPFRS-02 VCXO is still locked correctly onto the Rb atoms resonance.

A lock monitoring can be performed by the direct connection of CMOS gate input to the Vref output (pin 8) . An internal transistor collector will then pull down the reference voltage to 0 when the Rubidium is not locked.

### 4.8.1 TTL OR CMOS LEVEL 'LOCK MONITOR' GENERATION:

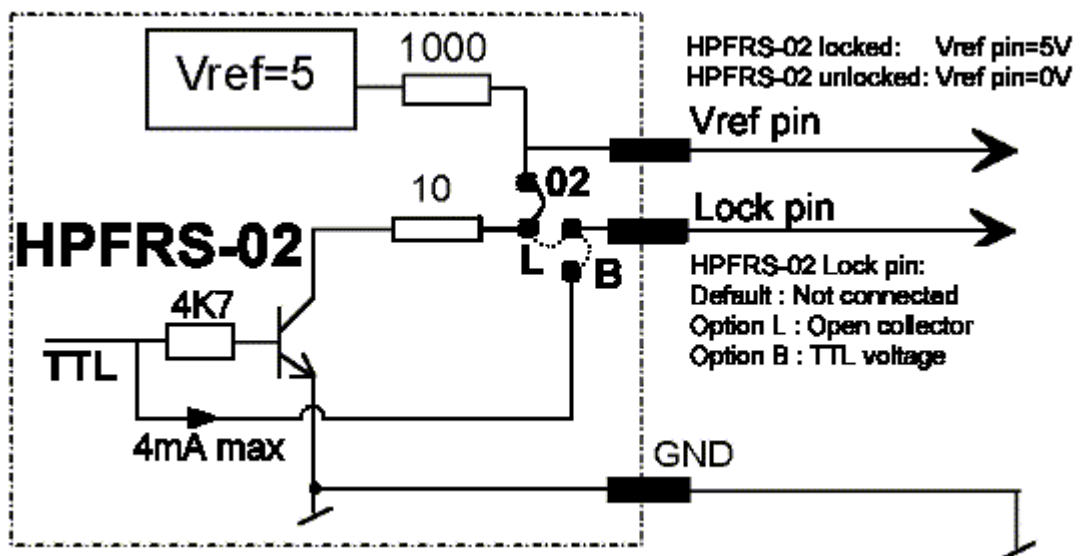

The lock monitor output pin of the HPFRS-02 option "L" can be directly connected to the CMOS load, or a pull-up resistor can be added for TTL compatibility. The HPFRS-02 option "B" provides an unprotected TTL output. Concerning the Lock pin (pin 1) and Vref pin (pin 8), different options are possible on the HPFRS-02 model:

	HPFRS-02	HPFRS-02-L	HPFRS-02-B
Lock pin: Locked	Not connected	Open (blocked)	<0.4V (TTL Low)
Lock pin: Unlocked	Not connected	< 0.4V / 10mA	>4V (TTL High)
Vref pin: Locked	5V reference	5V reference	5V reference
Vref pin: Unlocked	< 0.4V	0.4V reference	0.4V reference