

*Ultra-High Resolution FemtoStepper*

**100fs Resolution Phase Stepper**

*Easy-to-Use RF Device & Compact light weight*



Calibration | Time Transfer | Doppler Shift Compensation | Instrument

**Applications**

# Table of contents

- 1 FEMTOSTEPPER SYSTEM DESCRIPTION .....3**
  - 1.1 FREQUENCY ADJUSTMENT .....4
  - 1.2 PHASE ADJUSTMENT .....4
  - 1.3 MICROPROCESSOR CONTROL AND PPS (PULSE PER SECOND) FACILITY .....5
- 2 FEMTOSTEPPER INSTALLATION.....6**
  - 2.1 SAFETY .....6
  - 2.2 UNPACKING .....6
  - 2.3 ELECTRICAL & INDICATOR INTERFACES .....6
  - 2.4 CONNECTIONS .....8
  - 2.5 RECOMMENDATIONS .....8
  - 2.6 SYSTEM POWER-UP .....8
- 3 SYSTEM CONTROL .....9**
- 4 RS232 COMMANDS .....10**
  - 4.1 IDENTIFICATION .....10
  - 4.2 SERIAL NUMBER .....10
  - 4.3 STATUS .....10
  - 4.4 SINGLE PHASE STEP .....11
  - 4.5 PACKET PHASE STEP .....11
  - 4.6 ACTUAL PHASE ADJUSTMENT .....12
  - 4.7 FREQUENCY OFFSET .....12
  - 4.8 ACTUAL FREQUENCY OFFSET .....13
  - 4.9 PULSE PER SECOND ALIGNMENT .....13
  - 4.10 PPSOUT DELAY .....14
  - 4.11 INFORMATION EVERY SECOND .....14
- 5 MECHANICAL.....15**

# 1 FemtoStepper System Description

The FemtoStepper provides a highly stable 10MHz, available on four outputs, that is adjustable in phase and frequency with an extremely high resolution. In addition to the 10MHz outputs, the micro-stepper provides a one pulse per second (1PPS) available on four outputs generated from the 10MHz output.

The FemtoStepper provides a 10MHz signal that is derived from a high performance, ultra low phase noise crystal oscillator which is phase locked to an external 10MHz reference input. It allows to adjust the outputs in phase and frequency without disturbing the reference signal source and precautions are taken in order to minimize the added noise.

The design is based on a double heterodyne architecture where a first structure is used for positive phase / frequency adjustment and the second structure for negative adjustment.

The device is controlled remotely through an RS-232 serial link. which provides a prompt with a defined list of commands. All commands are parsed for correct syntax and operational range prior to execution. Commands that contain errors are rejected.

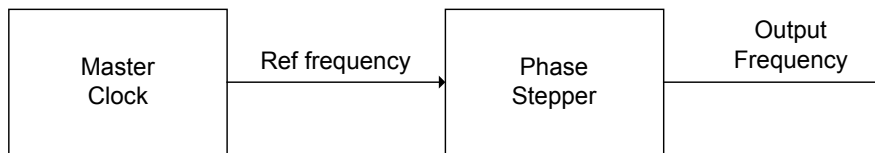

Figure 1- Application Diagram

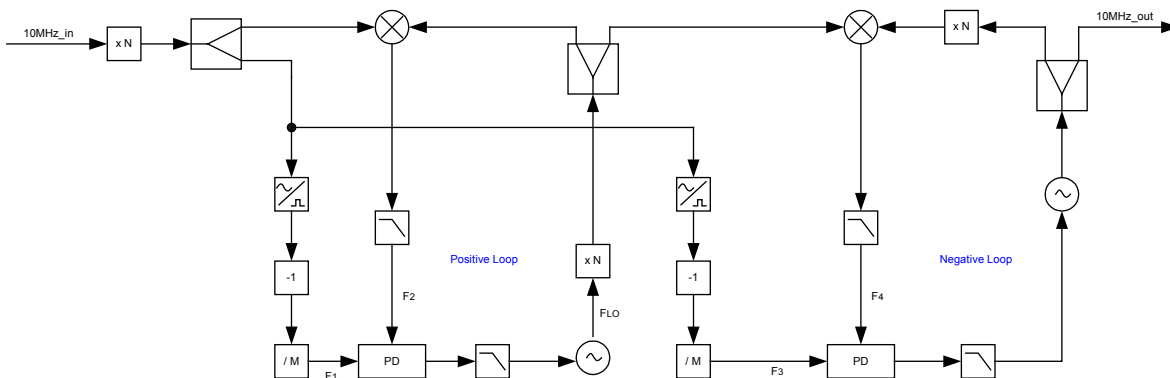

Figure 2- Block Diagram

## 1.1 Frequency Adjustment

The frequency offset is applied to the output 10MHz OCXO through the double heterodyne structure in order to increase the resolution.

$$F_{out} = F_{in} + \frac{\Delta f}{G}$$

Where :

G : Heterodyne Gain of  $10^6$ .

$\Delta f$  is managed by the microprocessor.

The relationship between the output frequency and the input frequency is the following :

$$F_{out} = \frac{F_{in}}{1 - \frac{N}{10^{17}}}$$

Where :

N : Frequency offset by  $10^{-17}$  steps.

The frequency offset is always the absolute value from the 10MHz input.

The output range is limited nearly  $\pm 10^{-9}$ . ( $\pm 9.9999999 \times 10^{-10}$ )

## 1.2 Phase Adjustment

The output phase is adjustable with 0.1 picosecond resolution over a maximum range of  $\pm 50$ ns in order to cover an entire period of the 10MHz output signal. The phase adjustment is performed under microprocessor control.

### 1.3 Microprocessor control and PPS (pulse per second) facility

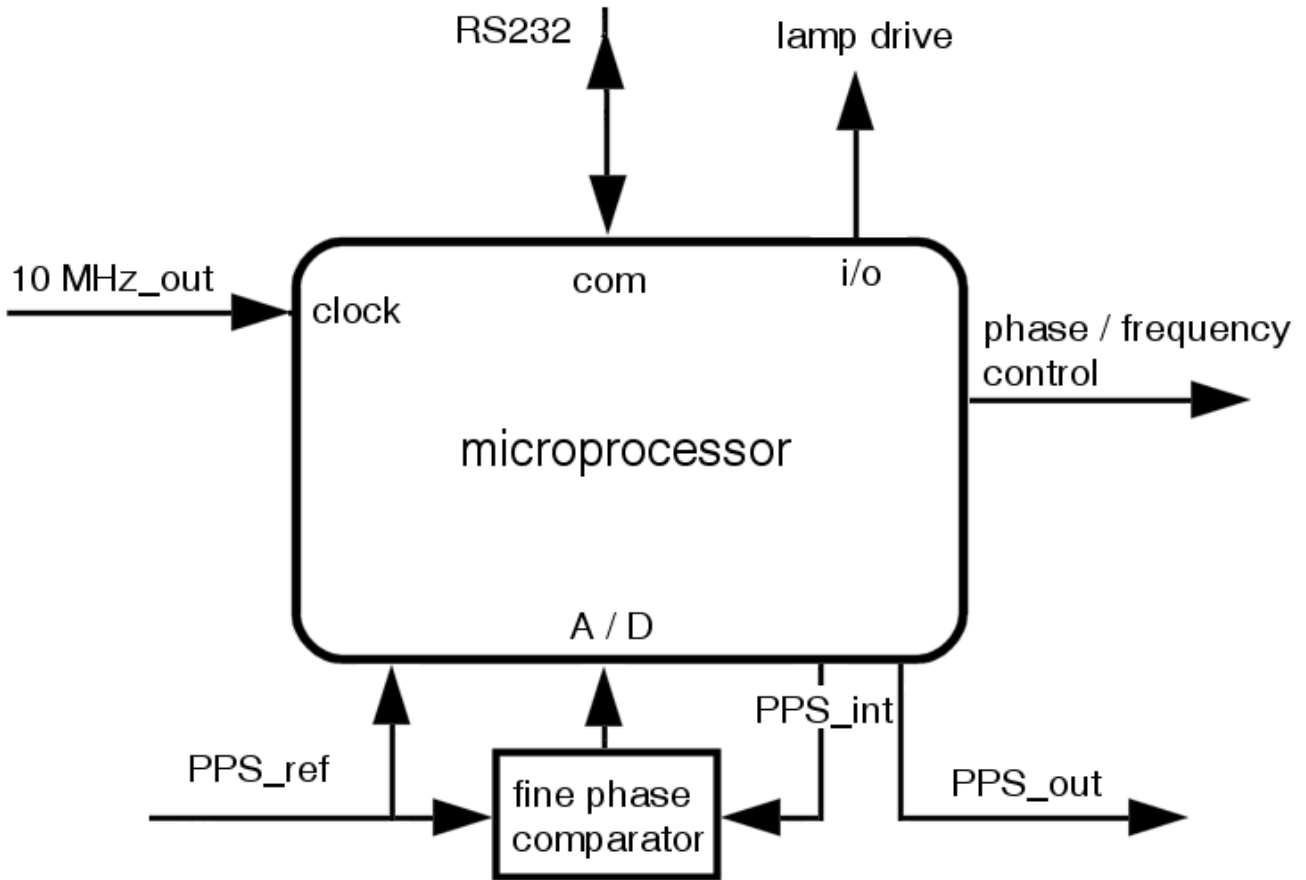

Figure 3 – The microprocessor and its surrounding

The microprocessor is controlling the functions. It is clocked by the 10 MHz\_out. A division by 1e+7 is made, providing the PPS\_out. The PPS\_out can be aligned to a reference PPS\_ref within +/- 200 ns when the command AL1 is issued. .

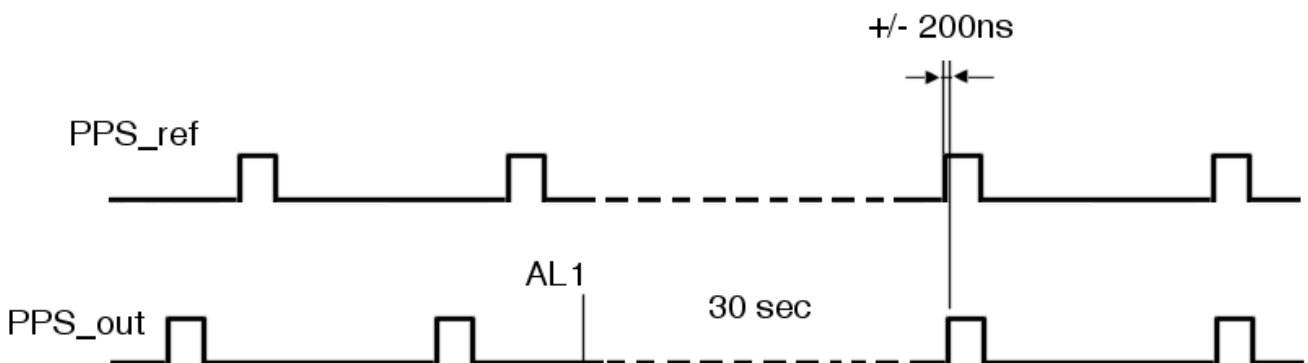



Figure 4 – The PPS\_out can be aligned to the PPS\_ref.

## 2 FemtoStepper Installation

### 2.1 Safety



- Use proper ESD precautions
- Ensure that all cables are properly connected

### 2.2 Unpacking

Unpack and carefully inspect the unit. Check for physical damage. If physical damage is observed, then immediately contact SpectraTime SA.

#### Unit Supply:

- 1 FemtoStepper Rack 19"/2U
- 1 Cable SUB-D 9 pins male/female
- 1 Euro power cable
- 2 Brackets for rack mount (only with standard version)
- 1 Connector for Backup DL power supply

### 2.3 Electrical & Indicator Interfaces

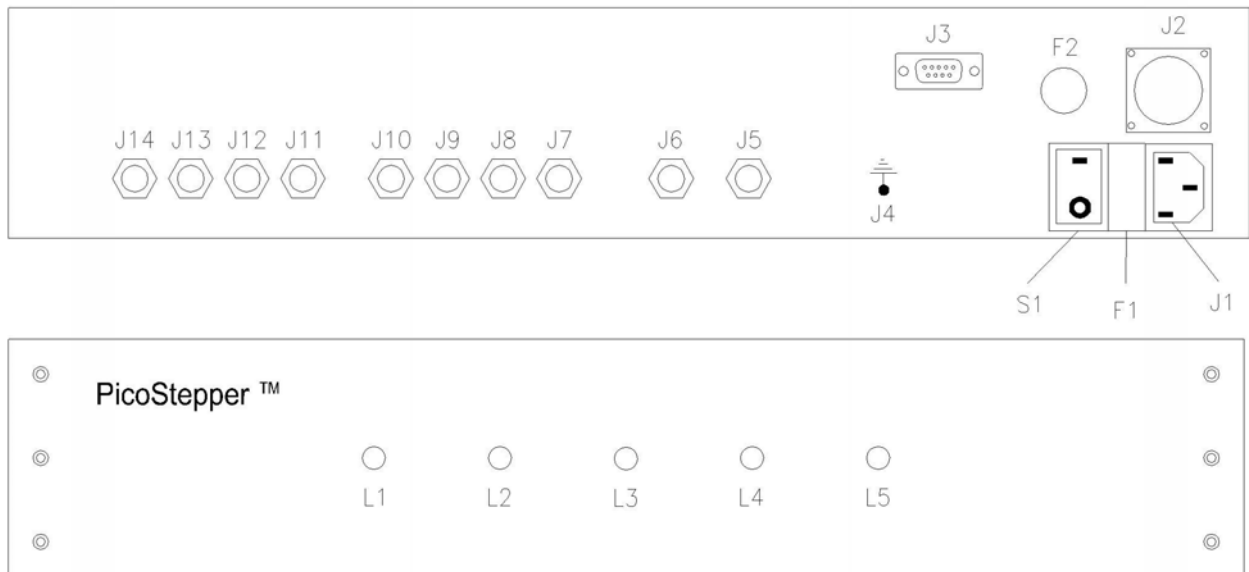

Fig. 3 Interfaces

N°	In/Out	Designation
J1	In	230VAC primary power
J2	In	+24VDC backup power
J3	In/Out	COM Interface
J4	-	Ground connection
J5	In	10 MHz reference signal
J6	In	PPS reference signal
J7-J10	Out	4x PPS output
J11-J14	Out	4x 10MHz output
S1	-	On/Off switch
F1	-	Primary power supply fuse - T 1,6A
F2	-	Backup power supply fuse - T 3,15A
L1	-	Primary power indicator
L2	-	Backup power indicator
L3	-	Alarm indicator
L4	-	Running indicator
L5	-	Initialization indicator

Table 1: Interfaces

	Pin	Designation
J2	1	GND VDC backup power
J2	2	+24 VDC backup power
J2	3	+24 VDC backup power
J2	4	GND VDC backup power

Table 2: Backup Power Connector

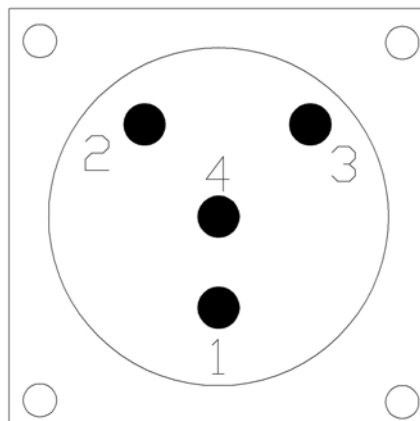

## 2.4 Connections

- Connect the **10MHz** input reference to the FemtoStepper unit (J5).
- Connect, if PPS functionality is desired, the PPSref signal (J6).
- Connect the male SUB-D-9 to the unit (J3) and female SUB-D-9 to the computer.
- Connect the primary power cable (230VAC) to the unit (J1).
- Connect the backup power cable (+24VDC) to the unit (J2).
- Optionally, connect the device to ground (J4).
- Switch on the unit (S1).

## 2.5 Recommendations

- Warm-up FemtoStepper **several hours** before to start any applications.
- To reduce warm-up time, keep FemtoStepper powered-up at all times even when an input reference signal is not available.
- To ensure a continuous operation, connect a uninterruptable backup 24V power source.
- Avoid locations of the unit with variable air flow and temperature changes.
- Avoid to place FemtoStepper close to vibration environment and high magnetic fields changes.

## 2.6 System Power-Up

- Switch on the unit (S1).
- If the primary power is connected, L1 indicator is green.
- If the backup power is connected, L2 indicator is green.
- The alarm indicator (L3) is red while warming-up.
- During the first five seconds, the microprocessor is performing an initialization. At the end of the initialization sequence, L5 switches off.
- After approximately fifteen minutes, the alarm (L3) indicator have to switch off. If still red, check if an input reference is connected (J5).
- When ready to operate the running indicator (L4) becomes green.
- When a frequency offset is applied, the running indicator (L4) is blinking.

### 3 System Control

The device is controlled remotely through an RS-232 serial link. which provides a prompt with a defined list of commands. All commands are parsed for correct syntax and operational range prior to execution. Commands that contain errors are rejected.

The RS232 protocol is :

- 9600 bits/s
- 8 data bits
- No parity
- 1 stop bit
- No handshake

FemtoStepper accepts the following basic ASCII commands: Data is in decimal ASCII code.

Command name	Syntax command	Data field (if any)	Response syntax	Response data (if any)
Identification	<b>ID</b> <CR><LF>	-	TNTMPS-aaa/tr/s.ss<CR><LF>	aaa: 001 tr: revision number s.ss: software version
Serial number	<b>SN</b> <CR><LF>	-	xxxxxx<CR><LF>	xxxxxx : 6 digits serial nbr
Status	<b>ST</b> <CR><LF>	-	yyxx<CR><LF>	yy : always 00 (for future use) xx : HEX ASCII  <u>Bit signification :</u> Bit 7 :- Bit 6 :backup power active Bit 5 :primary power active Bit 4 :- Bit 3 :frequency offset not 0 Bit 2 : stepping activity Bit 1 : OOL - Bit 0 : OOL +
Single Phase Step	<b>PS</b> s<CR><LF>	s=+ : Positive Step s=- : Negative Step	s<CR><LF>	s: signe s=+ : Positive Step s=- : Negative Step
Packet Phase Step	<b>PS</b> sdxxxxx<CR><LF>	s=+ : Positive Packet Step s=- : Negative Packet Step dxxxxx: number	sdxxxxx<CR><LF>	s:signe s=+ : Positive Packet Step s=- : Negative Packet Step dxxxxx: value
Actual phase offset	<b>PH</b> <CR><LF>	-	sdxxxxx<CR><LF>	s:signe s=+ : Positive Packet Step s=- : Negative Packet Step dxxxxx: value From 000000 To 500000
Frequency offset	<b>F</b> Asdxxxxxx<CR><LF>	s=+ : Positive offset s=- : Negative offset dxxxxxxx: number	sdxxxxxx<CR><LF>	s=+ : Positive offset s=- : Negative offset dxxxxxxx: value
Actual frequency offset	<b>FR</b> <CR><LF>	-	sdxxxxxx<CR><LF>	s=+ : Positive offset s=- : Negative offset dxxxxxxx: value
Align PPSOUT to PPSREF	<b>AL</b> d<CR><LF>	d= 1 : align d= ? : alignment status	d<CR><LF>	d= 0: ready for alignment d= 1: alignment in progress d= 2 : no PPSREF
Set PPSOUT delay (rounded to 200ns)	<b>DE</b> dxxxxxxx<CR><LF>	dxxxxxxx=delay in ns. Max 999999800 ???????? :interrogation	dxxxxxxx<CR><LF>	dxxxxxxx=delay in ns. Min 000000000 Max 999999800
Send information every second	<b>BT</b> x<CR><LF>	x= 0 : Stop to send x= 3 : PPSRef position x= 5 : Status	x= 3 : aaaaaaaaa sbbb<CR><LF> x= 5 : yyxx<CR><LF>	aaaaaaaa= PPSOUT vs PPSREF delay in ns. sbbb= fine phase comparator value in approx. ns yyxx= see ST command

Table 2 : Serial commands summary

## 4 RS232 Commands

### 4.1 Identification

**ID<CR>[<LF>]** : Identification

Answer : **TNTMPS-aaa/rr/s.ss<CR><LF>**  
 aaa : 001  
 rr : revision number  
 s.ss : software version

Example : **ID<CR>** answers **TNTMPS-001/01/1.00<CR><LF>**

### 4.2 Serial number

**SN<CR>[<LF>]** : Serial number

Answer : **xxxxxx<CR><LF>**  
 xxxxxx : 6 digits serial number

Example : **SN<CR>** answers **000015<CR><LF>**

### 4.3 Status

**ST<CR>[<LF>]** : Status

Answer : **yyxx<CR><LF>**  
 yy : always **00** (reserved for future use)  
 xx : HEX ASCII status :  
     bit 7 :--  
     bit 6 :backup power active  
     bit 5 :primary power active  
     bit 4 :--  
     bit 3 :frequency offset not 0  
     bit 2 :stepping activity  
     bit 1 : OOL negative loop  
     bit 0 : OOL positive loop

Example : **ST<CR>** answers **0068<CR><LF>**  
 (backup and primary power active, frequency offset applied, system locked)

Note : **BT5<CR>** send status once per second in the same format.

#### 4.4 Single Phase Step

**PSs<CR>[<LF>]** : Single phase step

s = +: 1 positive phase step of  $10^{-13}$  second  
 -: 1 negative phase step of  $10^{-13}$  second

Answer : **s<CR><LF>**  
 s : sign of the single phase step

Example : **PS+<CR>** answers **+<CR><LF>**

Note : Phase adjustment are not absolute value.

#### 4.5 Packet phase step

**PSsdddddd<CR>[<LF>]** : Packet phase step

s = +: positive phase adjustment  
 -: negative phase adjustment

dddddd : phase adjustment in  $10^{-13}$  second  
 000000 to 500000  
 000001 : minimum phase adjustment ( $\pm 1 \times 10^{-13}$  s)  
 500000 : maximum phase adjustment ( $\pm 5 \times 10^{-9}$  s)  
 000000 : no phase adjustment

Answer : **sdddddd<CR><LF>**  
 sdddddd : phase adjustment value

Example : **PS+000100<CR>** answers **+000100<CR><LF>**  
 (a positive phase adjustment of  $10^{-11}$  second is asked)

Note : Phase adjustment are instantaneous phase changes and are cumulative with previous phase changes.

## 4.6 Actual Phase Adjustment

**PH<CR>[<LF>]** : Actual phase adjustment

Answer : **sdddddd<CR><LF>**

s = +: positive phase adjustment  
- : Negative phase adjustment

dddddd : phase adjustment value in  $10^{-13}$  second step

Example : **PH<CR>** answers **-000020<CR><LF>**  
(an total actual negative phase adjustment of  $2 \times 10^{-12}$  second has been applied)

Note : The actual phase is the accumulated phase changes from the starting of the system. A frequency offset different from 0 reset the phase adjustment to 0.

Example :

At  $T_0$  the command PS+000002<CR> has been sent,  
At  $T_1$  the command PS-000007<CR> has been sent,  
At  $T_2$  the command PS+000009<CR> has been sent,  
At  $T_3$  the command PH<CR> answers +000004 which corresponds to the total accumulated phase adjustment applied until  $T_3$  ( $2-7+9=4 \times 10^{-13}$  second).

## 4.7 Frequency Offset

**FAssddddddd<CR>[<LF>]** : Frequency offset

s = +: positive frequency offset  
- : Negative frequency offset

ddddddd : frequency offset in  $10^{-17}$  step  
00000000 to 10000000  
00000001 : minimum frequency offset ( $\pm 1 \times 10^{-17}$ )  
99999999 : maximum frequency offset ( $\pm 9.9999999 \times 10^{-10}$ )  
00000000 : no frequency offset

Answer : **sddddddd<CR><LF>**  
sddddddd : frequency offset value

Example : **FA+00010000<CR>** answers **+00010000<CR><LF>**  
(a positive frequency offset of  $10^{-13}$  relative to input reference frequency is asked)

Note : Frequency offset are absolute value from input reference frequency. A new frequency offset overwrite the previous one.

## 4.8 Actual Frequency Offset

**FR<CR>[<LF>]** : Actual frequency offset

Answer : **sddddddd<CR><LF>**

s = +: positive frequency offset  
- : negative frequency offset

ddddddd : frequency offset in  $10^{-17}$  step

Example : **FR<CR>** answers **-00100000<CR><LF>**  
(a negative frequency offset of  $10^{-12}$  relative to input reference frequency is applied)

Note : Frequency offset are absolute value from input reference frequency. A new frequency offset overwrite the previous one.

Example :

At  $T_0$  the command FA+00600000<CR> has been sent,

At  $T_1$  the command FA-00020000<CR> has been sent,

At  $T_2$  the command FR<CR> answers -00020000 which is the actual frequency offset (it corresponds to the last frequency offset command applied before  $T_2$ .)

## 4.9 Pulse Per Second Alignment

**ALd<CR>[<LF>]** : PPSOUT alignment to PPSREF

d = 1 : align  
? : interrogation

Answer : **d<CR><LF>**  
0: ready for alignment  
1: alignment in progress  
2: no PPSREF

Example : **AL1<CR>** answers **1<CR><LF>**

Notes:

- While the command is in progress, an internal PPSLOCAL is aligned to PPSREF. This can take up to 30 seconds.
- The alignment is done within +/- 200 ns.
- After an alignment DE???????? answers 00000000<CR><LF>
- This command has no influence on the 10 MHz output.

## 4.10 PPSOUT Delay

**DEddddddddd<CR>[<LF>]** : Set a PPSOUT delay

ddddddddd : delay in ns  
 000000000 to 999999980  
 000000000 : no delay  
 000000200 : minimum delay  
 000000980 : maximum delay  
 ?????????? : interrogation

Answer : **ddddddddd<CR><LF>**  
 dddddddd : just asked delay

Example : **DE?????????<CR>** answers **000000000<CR><LF>**

Notes :

- After power on / Reset, the PPSOUT position is random.
- After the command AL1, the PPSOUT is aligned to PPSREF and the delay is settled to 0.
- This command has no influence on the 10 MHz output.

## 4.11 Information Every Second

**BTx<CR>[<LF>]** : send information once per second on the serial port

**x = 0** : stop to send

Answer : none

**x = 3** : PPSOUT vs PPSREF position

Answer : **aaaaaaaa sbbb<CR><LF>** once per second  
**aaaaaaaa** : raw PPSOUT vs PPSREF position in ns, rounded to 200 ns steps  
 000000000 : PPSOUT aligned to PPSREF  
 000000200 : minimum value  
 999999800 : maximum value  
 ?????????? : no PPSREF

**sbbb** : s : sign +/- ; bbb : analog fine PPS comparator value in approximately ns. PPSLOCAL vs PPSREF.

+000 : PPSLOCAL and PPSREF are perfectly aligned.

-500 : lowest value

+500 : highest value

Remark : the command AL1<CR><LF> must be sent first to bring the PPSLOCAL in the PPS phase comparator working range.

**x = 5** : Status

Answer : **yyxx<CR><LF>** once per second  
 See [Status](#) command for details

# 5 Mechanical

