

Interconnecting Motorola GPS & Spectratime Smart Rubidium SynClock+®

Interconnecting & Evaluating the System Performance of Motorola UT+ Oncore GPS & Spectratime Smart SRO-100 Rubidium SynClock+®

Contents

<i>Introduction</i>	1
<i>Interconnecting the Smart GPS/SRO SynClock+® Timing System</i>	2
<i>Simple GPS/SynClock+® PC Interconnection</i>	2
<i>Smart GPS/SynClock+® PC Interconnection</i>	4
<i>Smart GPS/Jumpstart SynClock+® Designer Kit Interconnection</i>	6
<i>Evaluating the Smart GPS/SRO SynClock+® System Performance</i>	7
<i>Test Equipment & Diagram</i>	7
<i>System Performance</i>	7
<i>Fast Q&A Support</i>	9
<i>Ordering Spectratime Smart SynClock+®</i>	9
<i>Obsolescence remark</i> :	9

Introduction

In this AppNote, Spectratime's Smart SRO-100 Rubidium SynClock+® is referred to as the "Smart SynClock+®" and Motorola's UT+ Oncore GPS is referred to as the "GPS".

The patented SynClock+® is the industry's first smart Rubidium clock, integrating a host of complex timing and synchronization functions all in one low-cost, ultra-small package. It intelligently synchronizes, disciplines and controls any Stratum-1 reference such as GPS, Cesium, Hydrogen Maser, and T1/E1 at cutting-edge 1ns (nanosecond) resolution. The SynClock+® utilizes SmarTiming+™ technology to perform the following functions, which were previously implemented externally on a separate circuit board:

- Multi-vendor GPS interface with auto-adaptive reference filtering, disciplining, control, and Time RAIM/Position Hold signal optimization
- Auto-adaptive Stratum-1 reference disciplining and jitter/wander/noise filtering between 0-100,000 at 1ns resolution, exceeding MTIE/TDEV G.823/T1.101 standards for T1/E1 reference
- Auto-adaptive frequency stability over fast temperature changes at 0.1°C resolution
- Auto-adaptive frequency stability over temperature range within 2E-11
- Programmable 1PPS output phase/time offset adjustments between 0-1 sec through a 1ns-phase comparator
- Programmable or hardware Sync/Track setting mode to either a) phase align 1PPSout from a 1PPS GPS reference through the Sync mode or b) to frequency track 1PPSout from a 1PPS Stratum-1 reference through the Track mode
- Programmable EEPROM for TIE performance measurements, frequency calibration and backup setting in case of power failure, and seamless software upgrades
- Standard RS-232 communication interface with user-friendly ASCII commands for control, configuration, fault, and performance management

The purpose of this AppNote is to help engineers quickly design a complete GPS and Rubidium timing reference solution. The AppNote addresses the following design issues:

- How to connect, set up, and monitor the Smart GPS/SynClock+® timing system

- What kind of cutting-edge performance can be achieved through the Smart GPS/SynClock+® timing system

Interconnecting the Smart GPS/SRO SynClock+® Timing System

Three types of interconnection setup can be performed with the Smart GPS/SynClock+® as follows:

1. Simple GPS/SynClock+® PC interconnection
2. Smart GPS/SynClock+® PC interconnection
3. Smart GPS/Jumpstart SynClock+® Designer Kit interconnection

The software of Smart SynClock+® automatically configures, controls and optimizes the GPS during startup.

Simple GPS/SynClock+® PC Interconnection

Hardware Setup

Figure 1 illustrates how to easily interconnect the Smart GPS/SynClock+® timing system through a PC interface.

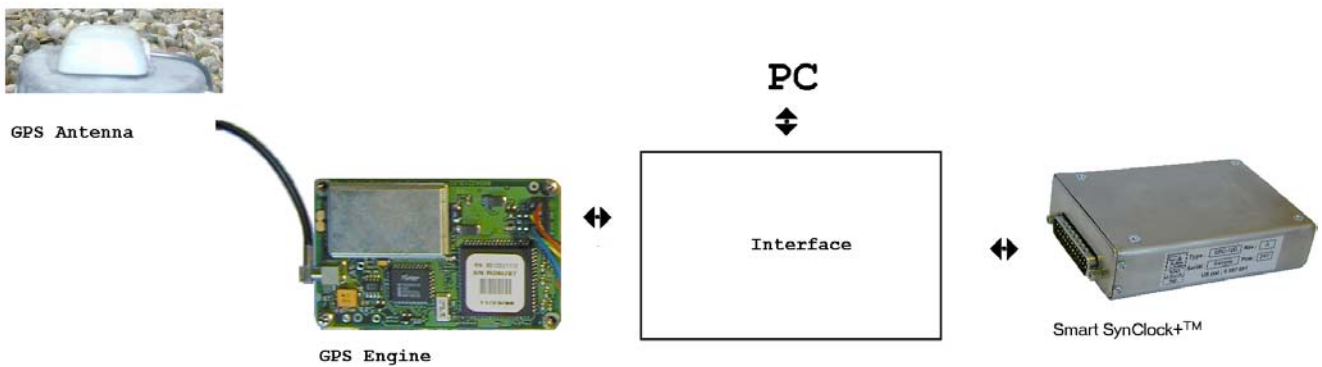

Figure 1 - Simple GPS/SynClock+® PC interconnection

PC Interconnection Interface

Figure 2 illustrates the PC interconnection interface, which allows communication to the Smart SynClock+®, but not to the GPS. The Smart GPS/SynClock+® PC interconnection allows communications with both the Smart SynClock+® and the GPS.

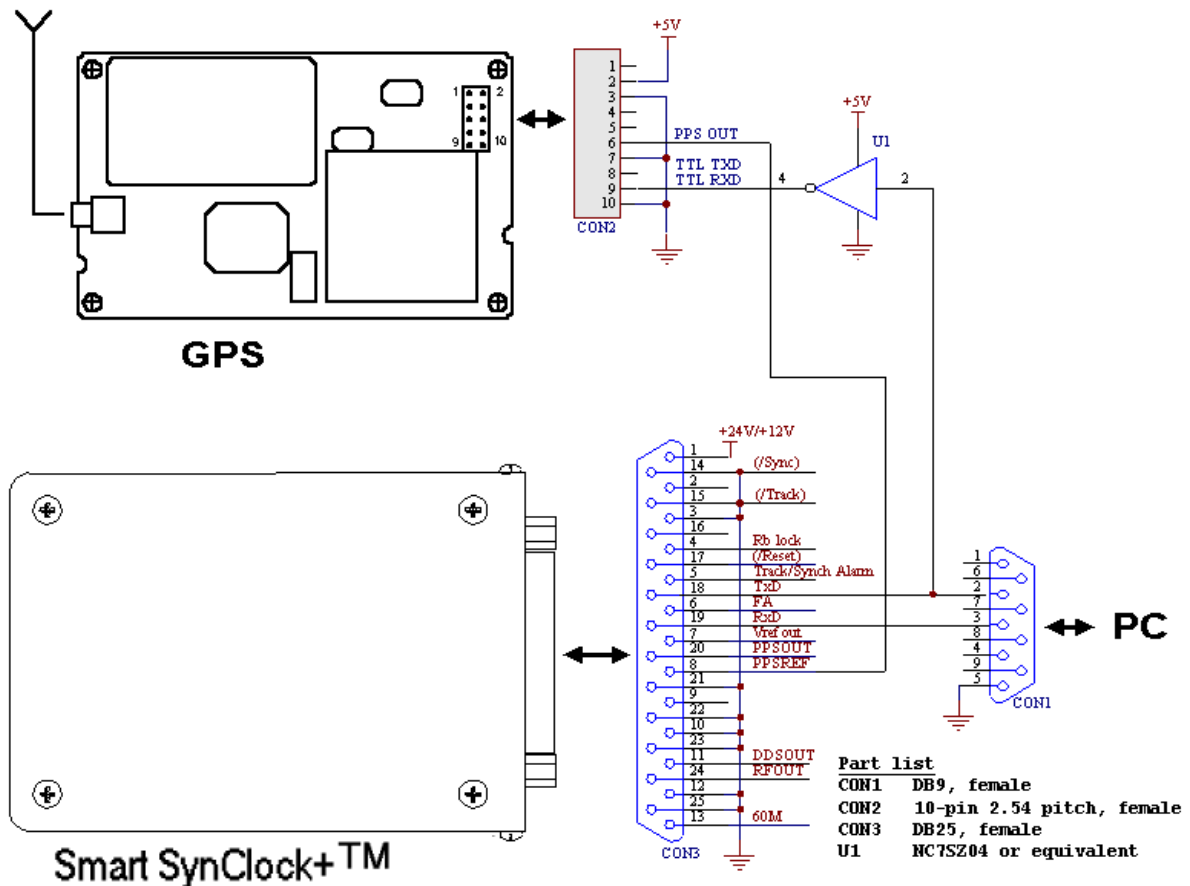

Figure 2 – PC Interconnection Interface

Software Setup

Simply follow the following instructions to set up the software interface of the Smart SynClock+®:

- 1) Connect the PC to the Smart SynClock+® through the serial port
- 2) Configure the GPS by running the ISyncMgr.exe application of the Jumpstart SynClock+® Designer Kit (JSDK). The application is also available at www.spectratime.com.
- 3) Click on the Timing+Tracking/MCsd menu and set up the Smart SynClock+® as illustrated in Figure 3:



Figure 3 – Smart SynClock+® GPS Setup

Message #	Description
2	It's a custom user message that can be activated to indicate that the Smart SynClock+® is used with a GPS
4 & 5	These are automatic vendor-specific configuration commands for the GPS

- 4) Power Off/On the Smart SynClock+®. During startup, it sends out configuration commands to the GPS
- 5) Click on the Timing+Tracking/ST menu

After >10 minutes, the status of the Smart SynClock+® should read “3 Sync to PPSREF”, indicating that it is properly disciplining by the GPS receiver. This status information can be read on the iSyncMgr software of the Smart SynClock+® or by a simple command ST<CR><LF> through a Windows terminal program.

Smart GPS/SynClock+® PC Interconnection

PC Interconnection Interface

Figure 4 illustrates the PC interconnection interface, which allows communication to both the Smart SynClock+® and the GPS, for the GPS commands start with “@@..” and are not recognized or ignored by the Smart SynClock+®. To monitor the GPS, the user must install the software program provided by the GPS vendor.

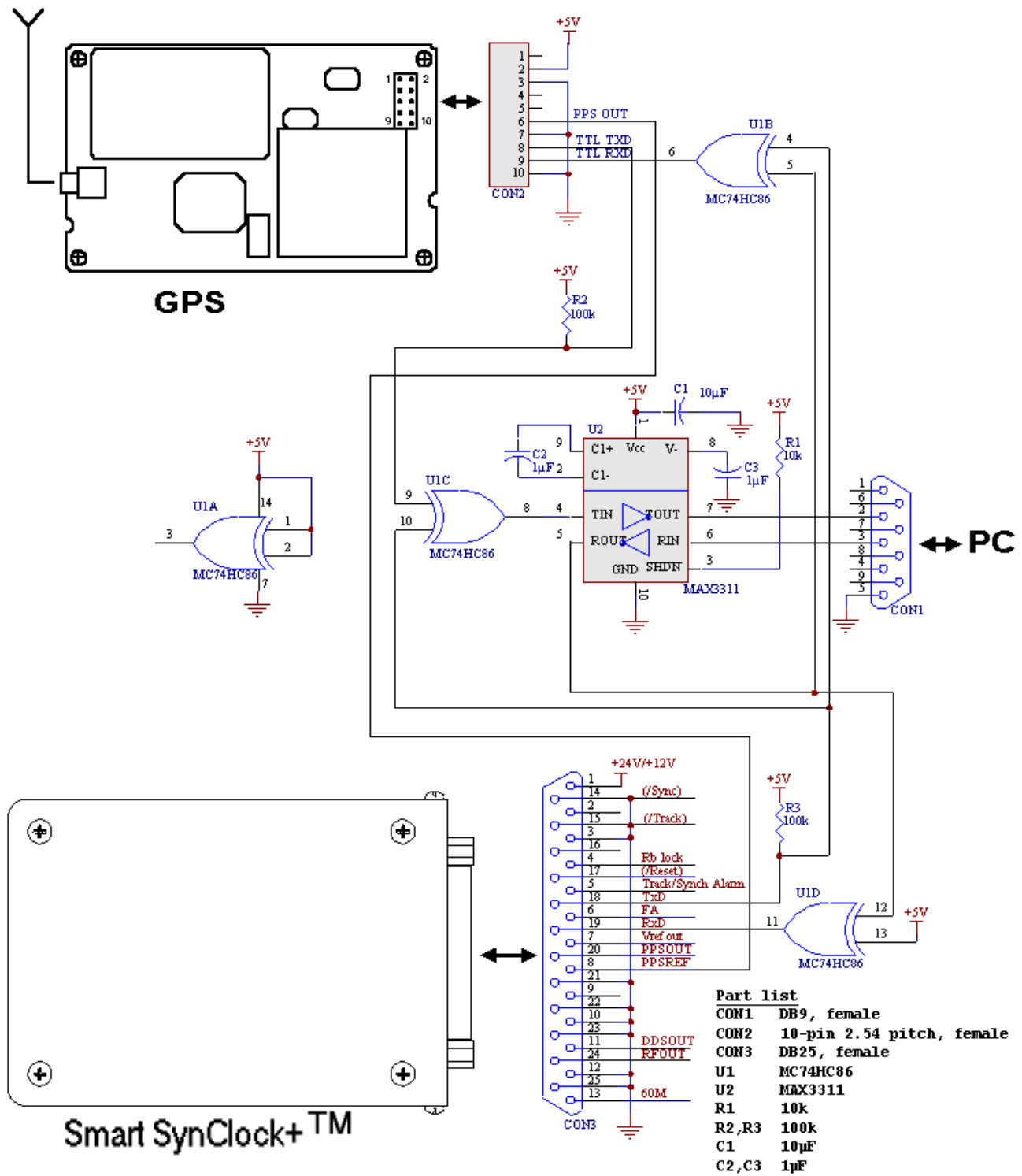

Figure 4 – Smart GPS/SynClock+® PC Interconnection

Software Setup

Simply follow the following instructions to set up the software interface of the Smart SynClock+®:

1. Connect the PC to the Smart SynClock+® through the serial port
2. Configure the GPS by running the ISyncMgr.exe application of the Jumpstart SynClock+® Designer Kit (JSDK). The application is also available at www.spectratime.com.
3. Click on the Timing+Tracking/MCsdd menu and set up the Smart SynClock+® as illustrated in Figure 3
4. Power Off/On the Smart SynClock+®. During startup, it sends out configuration commands to the GPS
5. Click on the Timing+Tracking/ST menu

After >10 minutes, the status of the Smart SynClock+® should read “3 Sync to PPSREF”, indicating that it is properly disciplining by the GPS receiver. This status information can be read on the iSyncMgr software of the Smart SynClock+® or by a simple command ST<CR><LF> through a Windows terminal program

Smart GPS/Jumpstart SynClock+® Designer Kit Interconnection

Designer Kit Interconnection Interface

Figure 5 illustrates the Jumpstart SynClock+® Designer Kit (JSDK) interconnection interface, which allows communication to both the Smart SynClock+® and the GPS.

During startup the JSDK sends configuration commands to the GPS through the standard RS-232 format (L:-5V, H:+10V). Since the GPS accepts only TTL inverted serial signals (L:+5V, H:0V), an inverting buffer must be inserted between the Smart SynClock+® and the GPS.

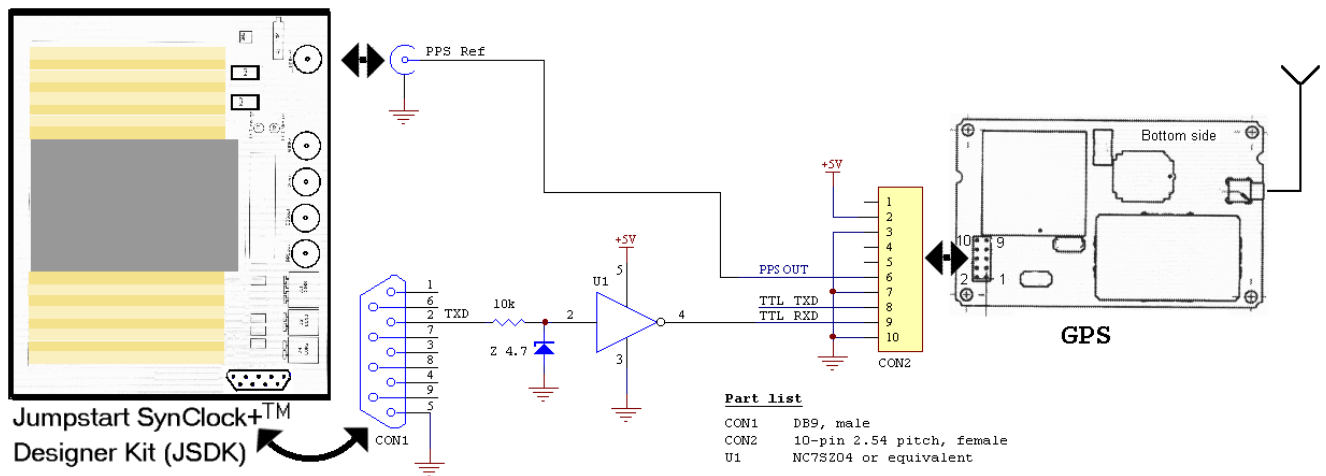

Figure 5 – Smart GPS/Jumpstart SynClock+® Designer Kit Interconnection

Software Setup

Simply follow the following instructions to set up the software interface of the Smart SynClock+®:

1. Connect the JSDK to the Smart SynClock+® through the serial port
2. Configure the GPS by running the ISyncMgr.exe application of the Jumpstart SynClock+® Designer Kit (JSDK). The application is also available at www.spectratime.com.
3. Click on the Timing+Tracking/MCsdd menu and set up the Smart SynClock+® as illustrated in Figure 3
4. Remove the serial communication to the PC and set up the connection as illustrated in Figure 5.
5. Set the hardware switches SYNC and Track on the JSDK to ON
6. Press the RESET button on the JSDK to auto-configure the GPS
7. Wait about 20 seconds before reconnecting the PC to the JSDK through the serial port

8. Power Off/On the Smart SynClock+®. During startup, it sends out configuration commands to the GPS
9. Click on the Timing+Tracking/ST menu

After >10 minutes, the green LED light on the JSDK should turn ON, indicating that the Smart SynClock+® is properly disciplining by the GPS receiver.

Evaluating the Smart GPS/SRO SynClock+® System Performance

Below is a series of typical cutting-edge phase performance graphs that can be achieved through the Smart GPS/SynClock+® timing system.

Test Equipment & Diagram

The following equipment was used to test and measure the performance of the Smart GPS/SRO SynClock+® system:

GPS Vendor:	Motorola at www.motorola.com/ies/GPS
GPS Product:	Motorola UT + Oncore GPS receiver, type R5122U1112
GPS Antenna:	Active antenna, type GCNAC111A
Spectratime Master Reference:	Hydrogen Maser, type H-MASER EFOS-C
Spectratime Clock:	Smart SRO-100 Rubidium SynClock+®
Counter Vendor:	Agilent, type 53131A counter
Notes:	A frequency difference of 3E-12 between the Hydrogen Maser and the GPS was removed to compute the performance data.

The testing diagram is as follows:

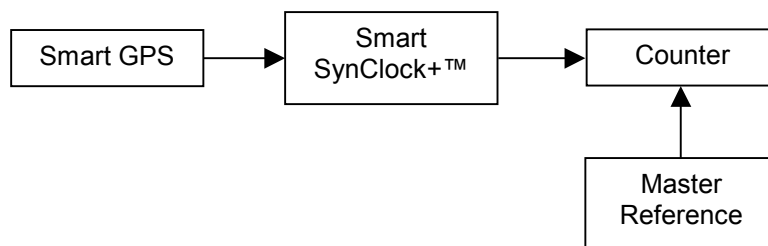

System Performance

Figure 6 illustrates the performance of the GPS which was installed in a poor location where the reception of the GPS signal was weak. The GPS was located on the balcony of Spectratime’s building in Neuchâtel, Switzerland. The building is located in a small valley which blocks the constant line-of-sight view of the satellites to the building’s balcony.

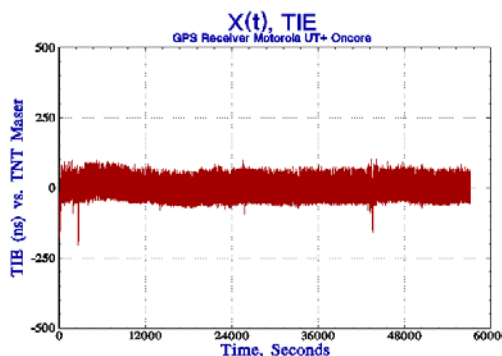

Figure 6 - GPS Time Interval Error Performance

The phase performance in Figure 6 is typical for a GPS receiver. The GPS was automatically set in Position Hold mode and the Time-RAIM was activated by the Smart SynClock+®.

The high noise of the GPS is called “clock granularity” by Motorola, and is due to the pulse generation system of the GPS.

Figure 7 illustrates the TIE holdover performance of Smart SynClock+® when the GPS reference is absent.

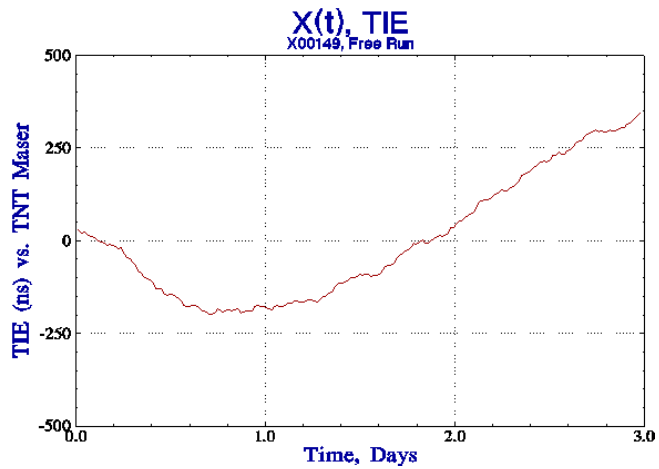

Figure 7 – Smart SynClock+® Holdover Performance

Figure 8 illustrates the MTIE Holdover performance of the Smart SynClock+® versus Stratum-1 ITU-T G.811 and ANSI T1.101 standard masks. The measurements were performed in a non-air-conditioned room, with typical temperature deviations of +/- 2°C.

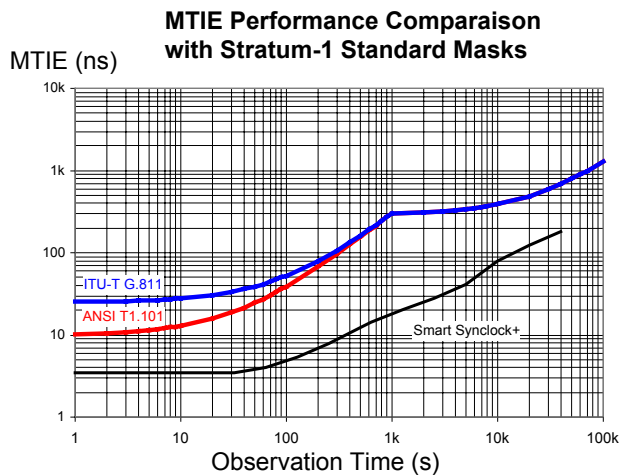

Figure 8 – Smart SynClock+® Holdover Performance vs. Stratum-1 Standard Masks

Figure 9 illustrates the TIE tracking performance of the Smart SynClock+® when locked to the GPS.

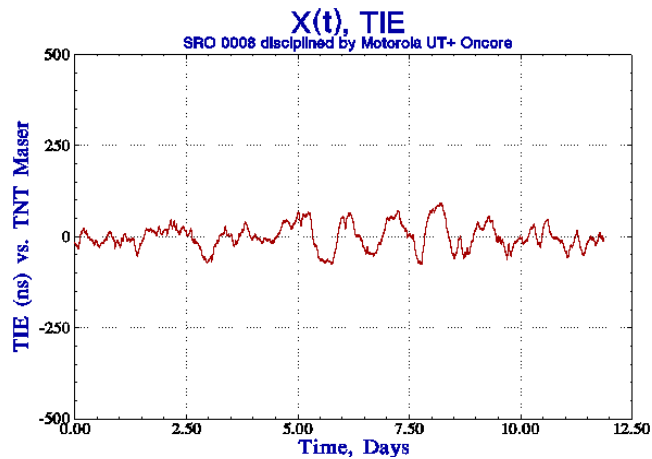

Figure 9 – Smart GPS/SynClock+® Tracking Performance

Figure 10 illustrates the MTIE tracking performance of the Smart GPS/SynClock+® versus Stratum-1 ITU-T G.811 and ANSI T1.101 standard masks.

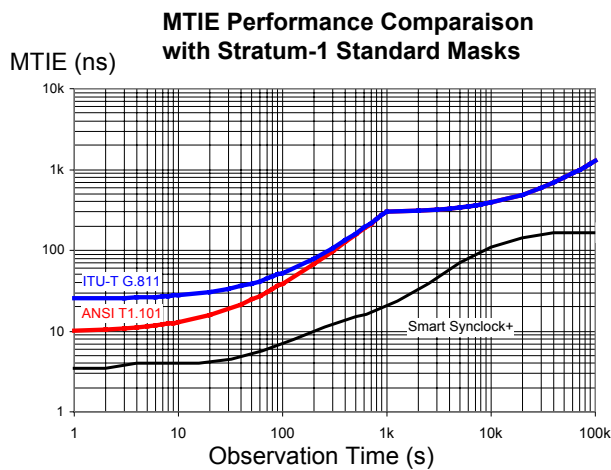

Figure 10 - Smart SynClock+® GPS Tracking Performance vs. Stratum-1 Standard Masks

Fast Q&A Support

If you have any questions about this AppNote or need tech support with your specific timing design and requirements, please feel free to contact us at fastsupport@spectratime.com.

Ordering Spectratime Smart SynClock+®

If you are interested in ordering the Smart SynClock+®, please contact us at sales@spectratime.com. For ordering the GPS, please contact Motorola at www.motorola.com.

Obsolescence remark :

Information given here is obsolete regarding hardware and software. Schematic of Figure 2 and Figure 4 are actual. This document is kept to show the performance.